

Information Display

Journal of the Society for Information Display



*Instant
computer access
from anywhere!*

with the **CONTROL DATA® 200** User Terminal

Your computer may be hundreds of miles away, but a CDC® 200 User Terminal puts its computing power at your fingertips . . . gives you immediate access to all the computing power you need, when you need it. Enter information or ask for it. Change or update a file. Submit a computing job. The response is immediate. In effect, the computer is yours alone, regardless of how many others happen to be using it simultaneously.

The CDC 200 User Terminal consists of a CRT/keyboard entry-display, a card reader and a printer. Data is entered via the keyboard. Response from the computer appears either on the screen or as hard copy from the printer.

The entry/display station has a 14" screen with a capacity of

twenty 50-character lines (thirteen 80-character lines optional). The photoelectric card reader has a capacity of 100 cards per minute. Its 1,000-character buffer gives it a throughput equal to that of larger, more expensive readers. In line printers, you have a choice between an 80 column or 136 column, 300-line-per-minute reader. Either device may also be used for off-line card listing.

For full details on this and other Control Data User Terminals, contact your Control Data Sales Office or write Dept. LL-78

CONTROL DATA
CORPORATION

8100 34th AVE. SO., MINNEAPOLIS, MINN. 55440

BERNARD J LECHNER
RCA LABORATORIES
PRINCETON NJ 08540
68
MIS

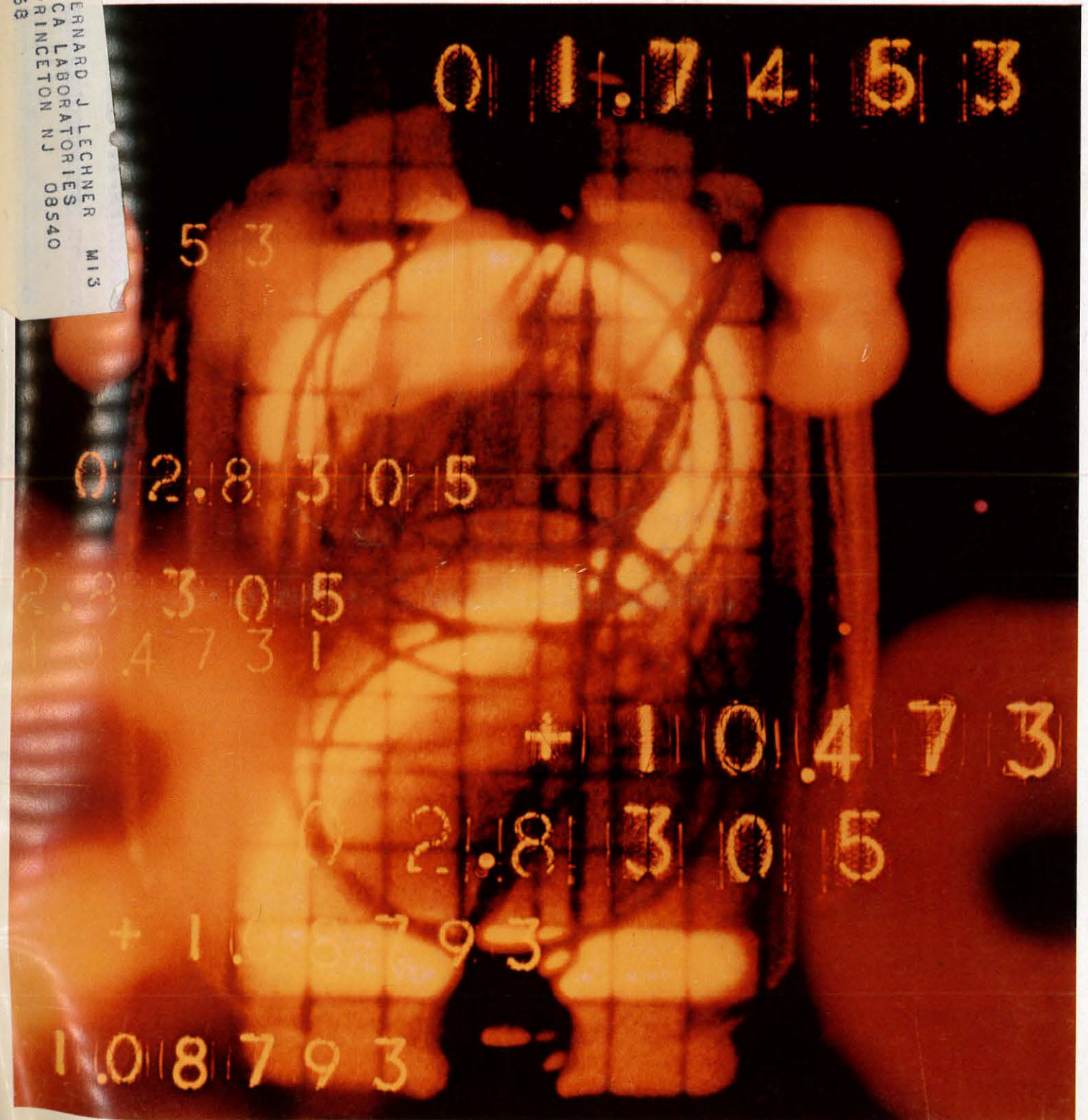

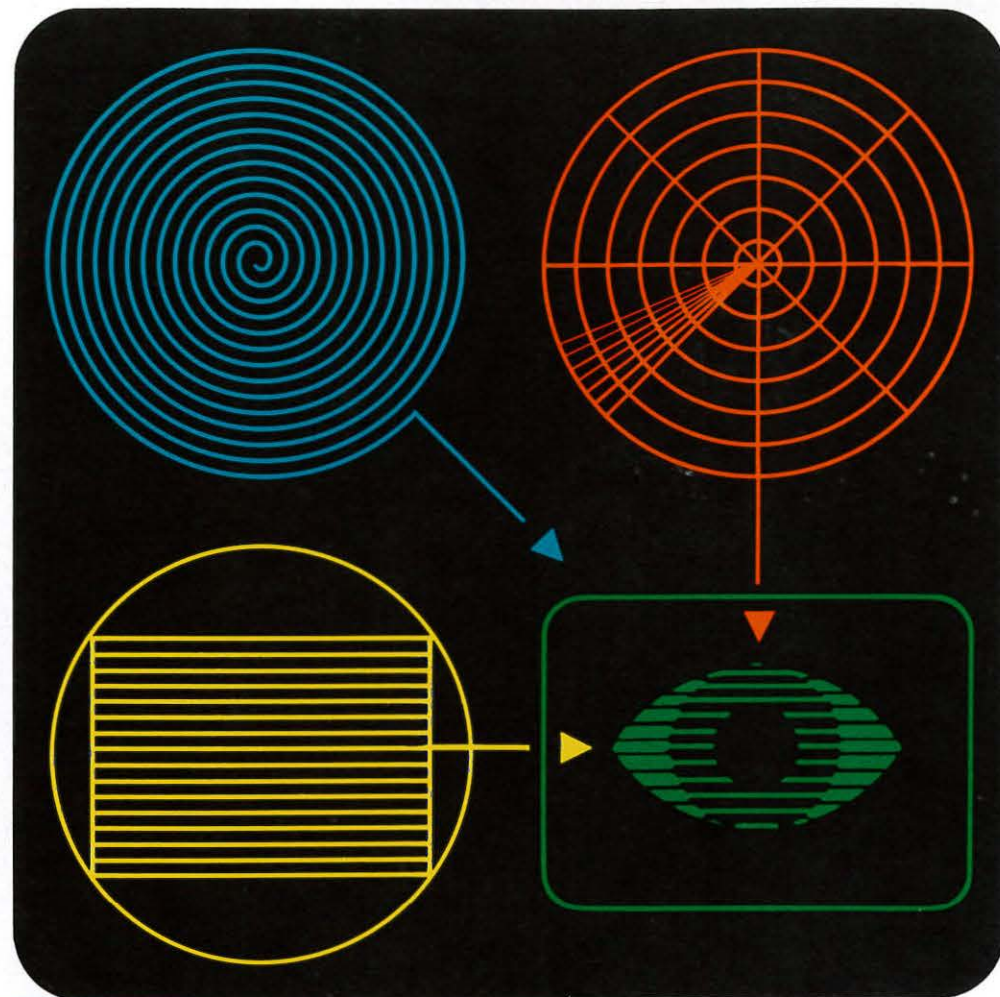

MSD— TODAY'S PRIME TASK FOR SCAN CONVERSION

- Other applications:
- Ultra fast (3 KMc) transient pulse recording and telemetry
 - Wave form analysis
 - Slow scan readout
 - Data storage and readout
 - Signal processing
 - and many more.

Think about scan conversion; when you are ready to talk about it, get in touch with the company that has the broadest experience in scan converter tubes. To receive some thought provoking literature, circle the number below:

Military ships and aircraft now on the drawing boards have eyes that see at night, under the sea, through clouds and over the horizon. More information is available than the decision maker can handle without special aid. The answer to the problem is MULTI SENSOR DISPLAY. MSD funnels radar, LLTV, Sonar imagery into a single TV display channel and permits the controller to query any of the available sensors at will via a bright display monitor.

The enabling ingredient is scan conversion. Input images are stored in their natural display format on the storage target of a Rauland scan converter tube. The readout beam dissects the stored image into the familiar TV video format. Reading and writing may be simultaneous and independent of each other. Display persistence is electronically controllable.

THE RAULAND CORPORATION • SPECIAL PRODUCTS DIVISION
5600 W. JARVIS AVENUE • CHICAGO, ILL. 60648 • Telephone (312) 647-8000 • A **GENIUM** Subsidiary

NEW high-brightness NIXIE® tubes. designed for tomorrow, delivered today.

TYPE B-5750

LOW COST:
\$3.95 each in 1000 quantities.

HIGH BRIGHTNESS:
time sharing up to 12 digits,
or for DC operation.

TUBE SIZE:
0.53" diameter; 1.5" height.



TIME-SHARING OPERATION:
like numerals can be driven in parallel,
reducing driver costs, and without sacrifice
of brightness.

IC-COMPATIBLE PIN CONFIGURATION:
dual-inline layout designed for IC decoder/
drivers.

OPTIONAL PIN CONFIGURATION:
conventional plug-in type for socket
mounting, or flying leads for direct
soldering.

COMBO PIN SPACER/LEAD STRAIGHTENER:
simplifies PC-board and/or socket insertion.

DECIMAL POINTS:
positioned left and right, independently
operable.

CHARACTER HEIGHT: 0.5"

MINI-SIZE, LOW-COST SOCKETS:
for DC or time-sharing operation.

ULTRA-RELIABLE:
like all ultra-long-life NIXIE tubes.

LONGEST STATIC LIFE:
for demanding applications.

SPECIAL-CHARACTER TUBES:
+/- tubes available from stock. Alpha/
special-character tubes made to order.

MOST COMPLETE HARDWARE BACK-UP:
low-cost IC decoder/drivers available
off-shelf. Custom assemblies at production
costs through modular design.

MOST COMPLETE APPLICATIONS BACK-UP:
design and applications assistance of
the kind available only from Burroughs,
the originator of NIXIE tubes. For a
demonstration, application notes and
full information call or write
Burroughs Corporation,
Electronic Components Division,
Dept. N-17, P.O. Box 1226,
Plainfield, New Jersey 07061
TEL: (201) 757-5000.

TYPE B-5855

LOW COST:
\$4.35 each in 1000 quantities.

ULTRA-HIGH BRIGHTNESS:
time sharing more than 12
digits, or for DC operation.

MINI TUBE SIZE:
0.51" diameter; 1.35" height.



TUBES SHOWN ACTUAL SIZE

Burroughs

Information Display

Journal of the Society for Information Display

table of contents articles

TRUE STEREOSCOPIC MOVIE SYSTEM WITHOUT GLASSES—Part 2 23
by Robert B. Collender
Conclusion of an article dealing with projection of stereo pictures to a large audience

EXPERIMENTAL EVALUATION OF THE RESOLUTION CAPABILITIES OF IMAGE TRANSMISSION SYSTEMS 31
by D. R. Knudson, S. N. Teicher, J. F. Reintjes, and U. F. Gronemann
Resolution capabilities of an experimental image-transmission system intended for a microfilm library application are investigated, using the modulation-transfer-function concept as a quantitative measure of component and overall-system performance

features

EDITORIAL: Rudolph Kuehn speaks on SID publications 10

MEDIA: 10th national symposium 44

READOUT: Display industry news 47

NEW PRODUCTS: Innovations from many firms 54

ON THE MOVE: People — their appointments, promotions 58

NEW LITERATURE: Data available on items and ideas 59

SUSTAINING MEMBERS 62

ADVERTISERS' INDEX: For finding them quickly 63

the cover

Shown on the cover is a digital voltmeter display manufactured by Dana Laboratories, Irvine, Calif. Photograph focuses on the digital readouts; Bradford Boston, of Boston & Boston Design, Los Angeles, arranged four color transparencies to create the abstract.

654 N. Sepulveda Blvd., Suite 5,
Los Angeles, Calif. 90049 (213) 472-3550

OFFICERS

PresidentCarl Machover
Vice-PresidentPetro Vlahos
SecretaryCarlo P. Crocetti
TreasurerErnest N. Storrs
Executive SecretaryH. R. Luxenberg

REGIONAL DIRECTORS

Northeast RegionRobert Klein
Harold R. Law
Edmund J. Kennedy
Southeast RegionJohn M. Snuggs
Anthony Rugari
Central RegionJ. E. Hoagbin
Robert N. Miller
William H. Libby
Western RegionW. R. Aiken
Joseph Stafford
James H. Redman

COMMITTEE CHAIRMEN

Definitions & StandardsSol Sherr
Honors & AwardsFordyce Brown
MembershipPhillip Damon
NominatingWilliam Bethke
ConventionRobert Woltz
PlanningG. Whitham & R. Bernberg
PublicityJohn Reynolds

PUBLICATIONS

[Prospective authors address inquiries to P. O. Box 1369, Huntington Beach, Calif. 92647]

Rudolph L. Kuehn, Chairman
Arthur F. Kochman Henry Parsons
Walter Lesiw Th. J. de Boer

EDITORIAL ADVISORY BOARD

William Ross Aiken Dr. Ruth M. Davis
Dr. Edith M. Baird Theodore Hamburger
William P. Bethke Dr. H. R. Luxenberg
Dr. Carlo P. Crocetti Petro Vlahos
Dr. A. M. Zarem

Published bi-monthly by
Information Display Publications, Inc.
647 N. Sepulveda Blvd. (213) 476-4711
Bel Air, Los Angeles, Calif. 90049

[Correspondence regarding advertising, reprints and non-membership subscriptions should be directed to the above address.]

EDITORS & PUBLISHERS ..Martin H. Waldman
Hal Spector

MANAGING EDITORCarol Summer
EDITORIAL ASS'T.L. Malevitz
PRODUCTION MANAGERClay Camburn
ART DIRECTORM. Weir
CIRCULATION MANAGERS. McDermaid
BUSINESS MANAGERS. Graham
ADVERTISINGIvan Berkoff
Donald Meecker

EDITORIAL OFFICES(213) 472-4414

CLOSING DATES—Editorial closing date is fifteenth day of the month preceding month of issue. Advertising closing is first day of the month of issue.

CHANGE OF ADDRESS notices should be sent promptly; provide old mailing label as well as new address; include ZIP code or postal code. Allow 2 months for change.

SUBSCRIPTION for U.S., its territories, possessions and Canada; \$12 per year. \$20 for two years. Single copy price, \$2.00; foreign countries, \$24 per year. \$40 for two years. Complaints concerning non-receipt of magazines must be made within four months of issue mailing date.

EDITORIAL CONTRIBUTIONS must be accompanied by stamped return envelopes and will be handled with reasonable care; however, publisher assumes no responsibility for safety of artwork, photographs or manuscripts. Every precaution is taken to ensure accuracy, but the publishers cannot accept responsibility for the correctness or accuracy of the information supplied herein or for any opinion expressed.

©1968 BY INFORMATION DISPLAY PUBLICATIONS, INC. ALL RIGHTS RESERVED. REPRODUCTION IN WHOLE OR PART WITHOUT WRITTEN PERMISSION IS PROHIBITED.

CONTROLLED CIRCULATION POSTAGE PAID
AT LOS ANGELES, CALIFORNIA

**SAVE
TIME
SPACE
MATERIAL**
in plotting your
digital data!

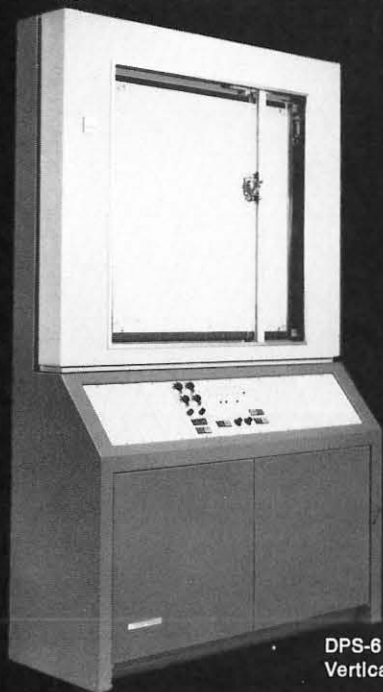

DPS-6
Vertical Plotter

THE SAVER

Match the cost-saving features of our DPS-6 vertical plotter with any other digital plotting system. DPS-6 gives you clear, accurate plots of your data with less programming time, less computer time, less I/O time and less plotting time. Saves on magnetic tape, data storage space and floor space. Choose the combination of X-Y plotter, input source and supporting software that meets your needs. Compare operating costs. You'll see why we call it "The Saver". Read about it in our brochure.



Milgo Electronic Corporation
Plotting Equipment Sales Division
7620 N.W. 36th Avenue
Miami, Florida 33147
Phone: (305) 691-1220

**SAVE
TIME
SPACE
MATERIAL**
in plotting your
digital data!



DPS-6
Horizontal Plotter

THE SAVER

This DPS-6 horizontal plotter offers the same cost-saving advantages as our vertical plotter. With either plotter, the DPS-6 Digital Plotting System gives you clear, accurate plots of your data with less programming time, less computer time, less I/O time, and less plotting time. The DPS-6 requires less magnetic tape and less space for data storage. Choose the combination of X-Y plotter, input source and supporting software that meets your needs. Compare operating costs. You'll see why we call it "The Saver". Read about it in our brochure.



Milgo Electronic Corporation
Plotting Equipment Sales Division
7620 N.W. 36th Avenue
Miami, Florida 33147
Phone: (305) 691-1220

Do you know what
it takes to make your
computer draw like this?

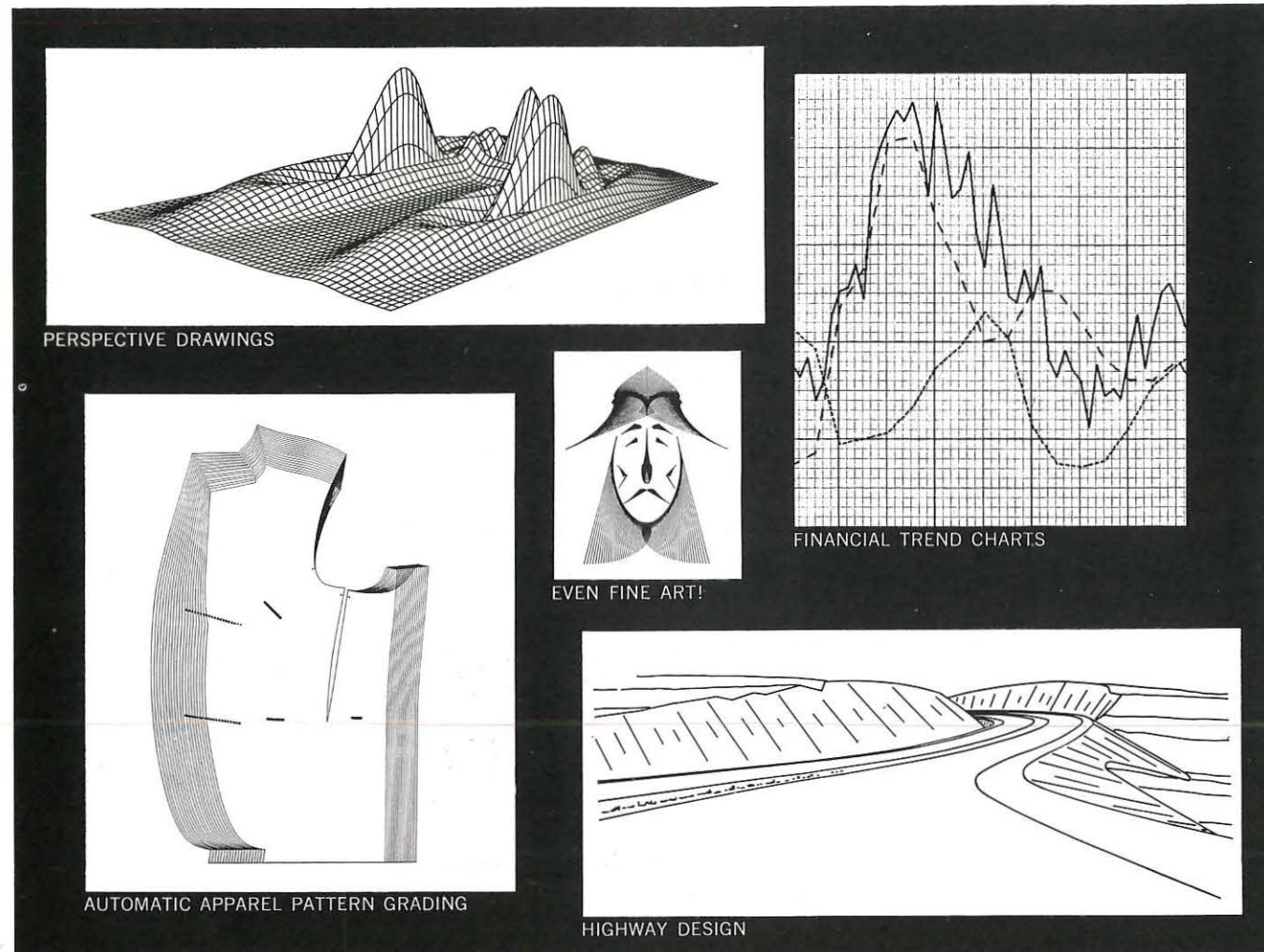

A CalComp System that's what.

All it takes is a CalComp Plotter and CalComp Software. You supply the computer and the problem, CalComp will supply the graphic solution. Call or write: Dept. Y-10, California Computer Products, Inc., 305 Muller St., Anaheim, California 92803. Phone (714) 774-9141.

CALCOMP
Standard of the Plotting Industry

(TALENTED ENGINEERS AND PROGRAMMERS REQUIRED — RIGHT NOW.)

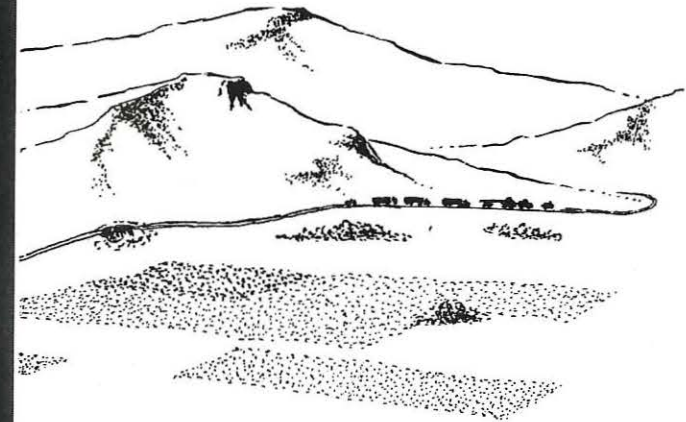
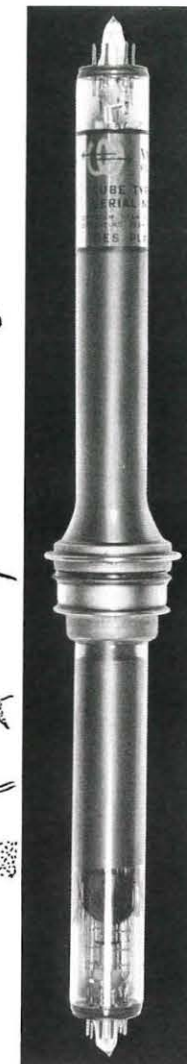
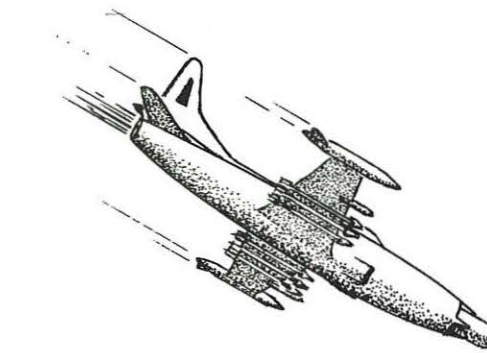

MINIATURE SCAN CONVERTER TUBE

The RW-5EM is a miniaturized, dual gun, electrical output storage tube capable of receiving an electrical input in one scanning mode, writing this information on the storage surface by the EBIC principle, and reading out the stored information with a scanning mode which is independent of the input. Small size and high resolution make this tube especially attractive for airborne and space applications. Increased circuit simplicity is inherent since the tube requires no dynamic focusing or crosstalk cancellation.



WARNECKE
ELECTRON TUBES, INC.
175 West Oakton Street, Des Plaines, Illinois 60018

Editorial

This issue marks the fourth anniversary of *Information Display*. Both the Society and its journal have clearly grown and matured in the intervening years, filling the need for a technical and scientific meeting place dealing with display problems. Since its inception, the Society journal has maintained a policy of publishing original material of significant technical merit as well as that of general interest. In keeping with the basic *SID* premise that it must serve its membership, the publications activities have been carefully examined with the result that a number of noteworthy changes have been made.

Elsewhere in this issue is an announcement of a new technical publication to appear quarterly. The *Proceedings of the Society for Information Display* becomes a natural successor to the earlier series of Technical Session Proceedings. The new publication will be typeset and composed in keeping with the best professional standards of the printing trades. Whereas the *SID* journal *Information Display* will continue to provide its broad coverage of industry, product, and Society news, sound technical articles, and pertinent advertising, the *Proceedings* will offer to *SID* members in-depth and tutorial treatments of the scientific and engineering developments of interest to the display field. Thus the two publications will complement each other, enhance the advantages of *SID* membership, and create a comprehensive base of display literature.

In order to carry out the plans for further and improved publications services — more of which will be announced in the near future — a larger and internationally represented Publications Committee has been formed. Prospective authors are encouraged to contact any *SID* chapter or regional representative as well as committee member for advice regarding possible publication. The increasing scope of Society publications assures that no worthwhile paper need wait long before appearing in print.

RUDOLPH L. KUEHN
Chairman/Publications

Won't wash out in the sun.

Our sunproof CRT is more than just a bright tube. It's an entirely new approach to high-ambient displays.

Sylvania developed special phosphors, filters and polarizers to make a tube that minimizes wash-out under extreme light conditions—even 10,000 foot-candles.

The result is a full family of high-contrast display devices. Readouts you can read in high ambients. They're available in any size from 1" to 27" with resolutions equivalent to conventional CRTs. You can take your choice of tube geometries and deflection systems.

If bright light is your problem, Sylvania's sunproof tubes are your answer.

Sylvania Electronic Components
Electronic Tube Division
Seneca Falls, N.Y. 13148

SUNPROOF CRTs BY
SYLVANIA
a subsidiary of
GENERAL TELEPHONE & ELECTRONICS

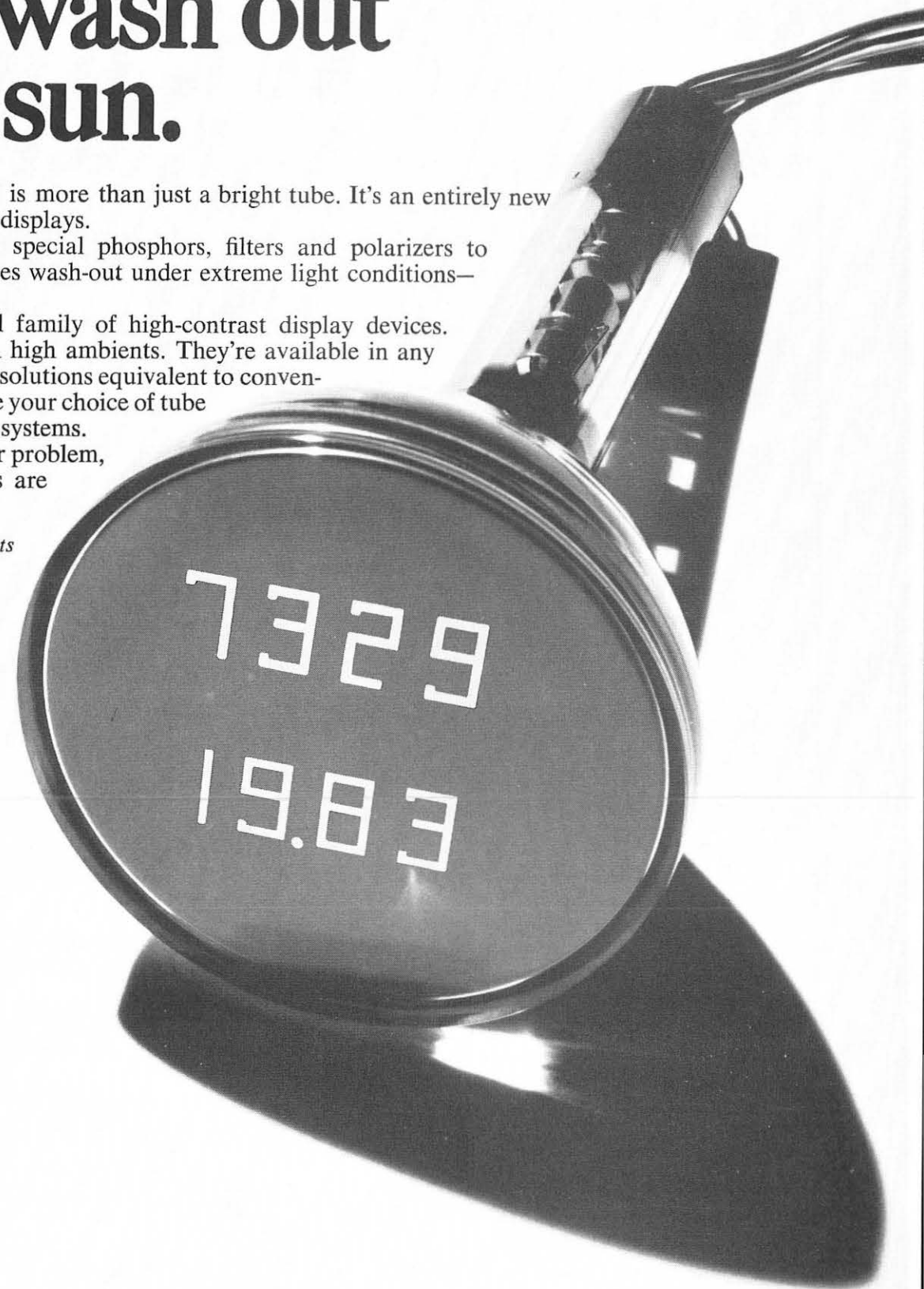

DISPLAY-POWER

PROVIDES DISPLAY DESIGNERS THE POWER TO CHOOSE THE BEST YOKES, CIRCUITS, AND DRIVERS FOR ALL THEIR CRT DISPLAYS

YOKE-POWER

CELCO STANDARD CATALOGUE YOKES MAY BE CHOSEN FOR BEST PARAMETERS REQUIRED IN YOUR DISPLAY.

LOW RESIDUAL MAGNETISM
FASTEST RECOVERY AND RISE TIMES
WIDE RANGE OF INDUCTANCES



HIGH-SPEED LOW-COST
HIGH-RESOLUTION
MAXIMUM SENSITIVITY

CIRCUIT-POWER

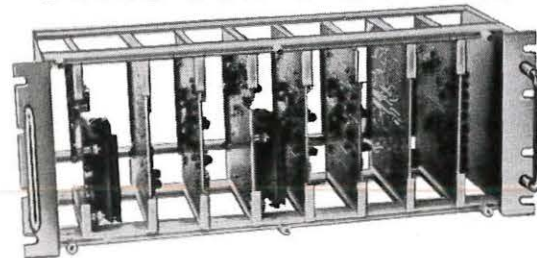

BLANKING, AND CRT PHOSPHOR PROTECTION
—Celco Blanking Amplifier And Phosphor Protection Circuit

CORRECTS NON-LINEARITY ON CRT FACE (X), LINE SCANS; (X, Y), RASTER DISPLAYS
—Celco Linearity Correction Circuits

MAINTAINS SPOT FOCUS OVER CRT FACE
—Celco Dynamic Focus Function Generator And Amplifier

CONSTANT CURRENT SUPPLY TO THE TWO AXES OF CENTERING, ALIGNMENT, OR STATIC ASTIGMATIC CORRECTION COILS:
—Celco Centering Coil Regulator

DRIVER-POWER



40 VOLT DEFLECTION AMPLIFIER
BEST LINEARITY, FASTEST SPEEDS
WITH NO RINGING NO OVERSHOOT

16 Amp Change In 12 μ sec.
Using 25 μ h Yoke.

0.02% Linearity
Amplifier Ranges Available:
0.5 to 16 Amps 20 and 40 Volts

Compatible With Celco Single-Ended Yokes; With or Without Quadru-Power-Supply.



Constantine Engineering Laboratories Company

Mahwah, N. J. 201-327-1123

Upland, Cal. 714-982-0215

What's happening today in keyboards is what's happening at MICRO SWITCH



Typical Communications Keyboard
Shown Below: Typical Data Preparation Keyboard

An important key to future keyboard design is what's happening at MICRO SWITCH.

Already we have successfully launched Happening No. 1: Introduction of complete wired and encoded keyboards ready to interface with your equipment.

Shown here are two typical keyboards. Each gives you dry reed switch input, solid-state-encoding, and a variety of exclusive options.

And they provide a flexibility that is unavailable elsewhere. You get a customized keyboard. Key array, format, added options, code change—you select the features required for your system.

Options include strobe and electrical monitor outputs, bounce gates and shift. For example, two interlock options are provided to improve operator speed and efficiency. An electrical monitor output triggers a detector circuit for blocking data or initiating error signals. A unique two-key rollover option permits typing at "burst" speeds without generating erroneous codes.



MICRO SWITCH

FREEMONT, ILLINOIS 61032

A DIVISION OF HONEYWELL

But that's not all. Coming very soon is Happening No. 2. Through advanced design concepts, complete engineering facilities, innovative assembly techniques, and unique quality assurance procedures, MICRO SWITCH is preparing to supply your every keyboard need. This means new reliability and flexibility in mass-production quantities with attractive customized appearance giving new sales appeal to your equipment.

Make no decisions on keyboards until you see what's happening at MICRO SWITCH. Call a branch office or call us at Freemont: phone 815/232-1122.

HONEYWELL INTERNATIONAL • Sales and service offices in all principal cities of the world. Manufacturing in United States, United Kingdom, Canada, Netherlands, Germany, France, Japan

Tear out this page.



This Dialight demonstrator unit (shown actual size) is available for your personal evaluation.

Place it next to any readout you're now considering. Then walk back 30 feet and prove to yourself that low-cost Dialight readouts are easier to read.

The only way to be sure is to compare Dialight readouts with others. This little test will give you a rough idea of the difference. But it's not quite as convincing as the actual demonstration we'll be happy to provide you with on request.

Dialight readout modules cost as little as \$3.99 each (less lamps in 1000 lot quantities). They operate on 6, 10, 14-16, 24-28 volts AC-DC, 150-160 volts DC and 110-125 volts AC. Caption modules are available; each is capable of displaying up to six messages at one time.



Windows are of non-glare type in a choice of colors.

Options: universal BCD to 7-line translator driver, 10-line to 7-line converter for decimal input, RFI-EMI suppression screen. Custom translators available.

To arrange to borrow a Dialight demonstrator unit, write us on your company letterhead.

For copy of our current catalog, circle reader service number below. Dialight Corporation, 60 Stewart Ave., Brooklyn, N.Y. 11237. (212) 497-7600.

DIALIGHT

Now,
from the makers
of the best...

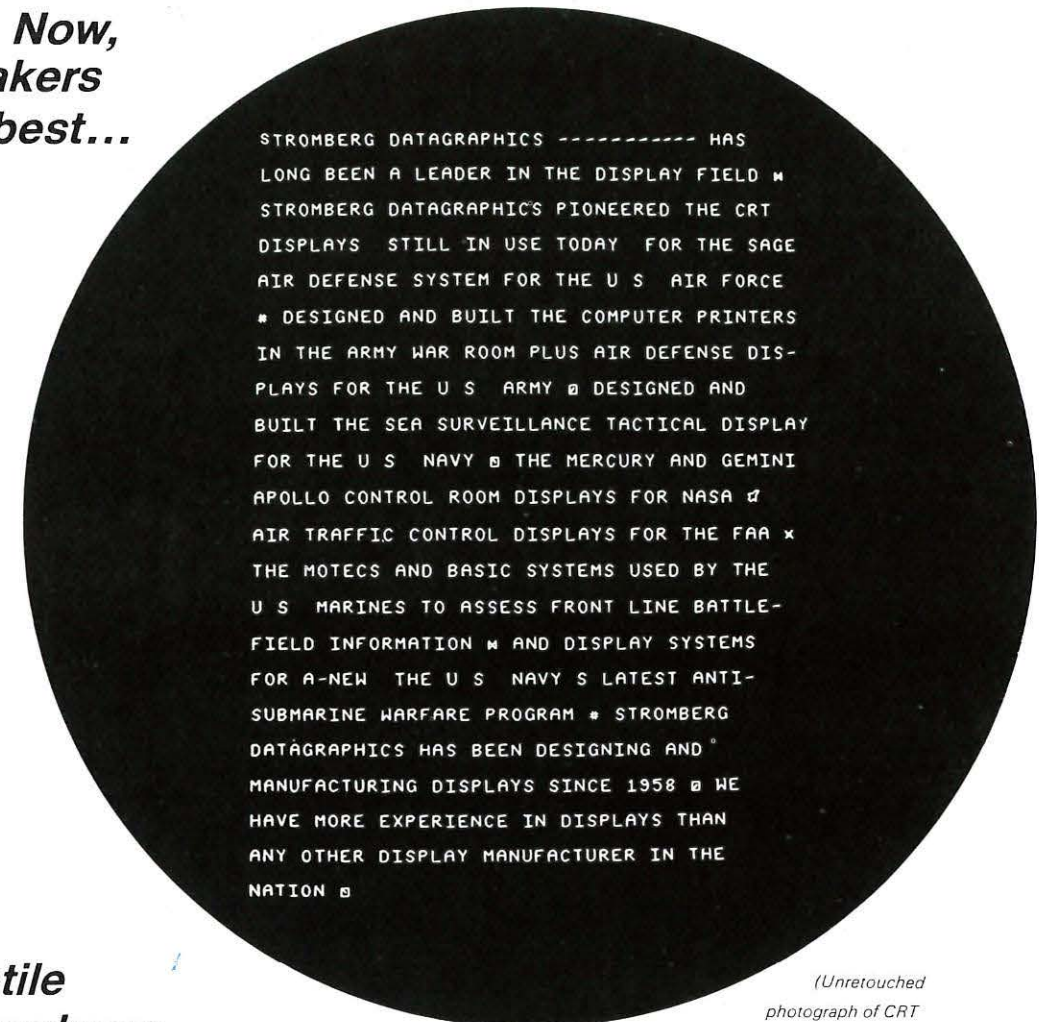

STROMBERG DATAGRAPHICS ----- HAS LONG BEEN A LEADER IN THE DISPLAY FIELD * STROMBERG DATAGRAPHICS PIONEERED THE CRT DISPLAYS STILL IN USE TODAY FOR THE SAGE AIR DEFENSE SYSTEM FOR THE U S AIR FORCE * DESIGNED AND BUILT THE COMPUTER PRINTERS IN THE ARMY WAR ROOM PLUS AIR DEFENSE DISPLAYS FOR THE U S ARMY * DESIGNED AND BUILT THE SEA SURVEILLANCE TACTICAL DISPLAY FOR THE U S NAVY * THE MERCURY AND GEMINI APOLLO CONTROL ROOM DISPLAYS FOR NASA * AIR TRAFFIC CONTROL DISPLAYS FOR THE FAA * THE MOTECs AND BASIC SYSTEMS USED BY THE U S MARINES TO ASSESS FRONT LINE BATTLE-FIELD INFORMATION * AND DISPLAY SYSTEMS FOR A-NEW THE U S NAVY S LATEST ANTI-SUBMARINE WARFARE PROGRAM * STROMBERG DATAGRAPHICS HAS BEEN DESIGNING AND * MANUFACTURING DISPLAYS SINCE 1958 * WE HAVE MORE EXPERIENCE IN DISPLAYS THAN ANY OTHER DISPLAY MANUFACTURER IN THE NATION *

(Unretouched photograph of CRT display produced by the new Stromberg Datagraphics Sequential Stroke Generator)

...a
versatile
new package

We're the people who make the CHARACTRON® Shaped Beam Tube displays. The CRT displays with the clearest and easiest-to-read characters in the industry. Now we've added a new dimension.

A remarkably versatile CRT sequential stroke generator utilizing an efficient new stroke-writing technique. It can generate as many strokes per character as needed: 14, 16, 24, 32, or more. Lightweight, it only weighs 2 lbs. Compact, you can carry it in a cigar box. Rugged, the U.S. Navy is using it in the A-NEW carrier based developmental system. Fast, it produces complete alphanumeric characters in 2 microseconds. Flexible, you can add or delete characters in minutes, or change a complete character repertoire, by merely inserting simple pre-

wired code strips. Economical, a version is currently being used in commercial data processing equipment.

This new technique complements our overall display generation capability. It is used separately and in combination with CHARACTRON tube systems as best fits the application.

But perhaps the best part of all, is that this new stroke generator is built by Stromberg Datagraphics—builders of the CHARACTRON Shaped Beam Tube displays. Everything about the exciting Stromberg Datagraphics Sequential Stroke Generator is new, and we've even retained the famous Stromberg quality.

Which is still the best.

**Moving
more information,
more places,
on time.**

Stromberg Datagraphics, Inc.

DISPLAY SYSTEMS

P.O. Box 2449 • San Diego, California 92112

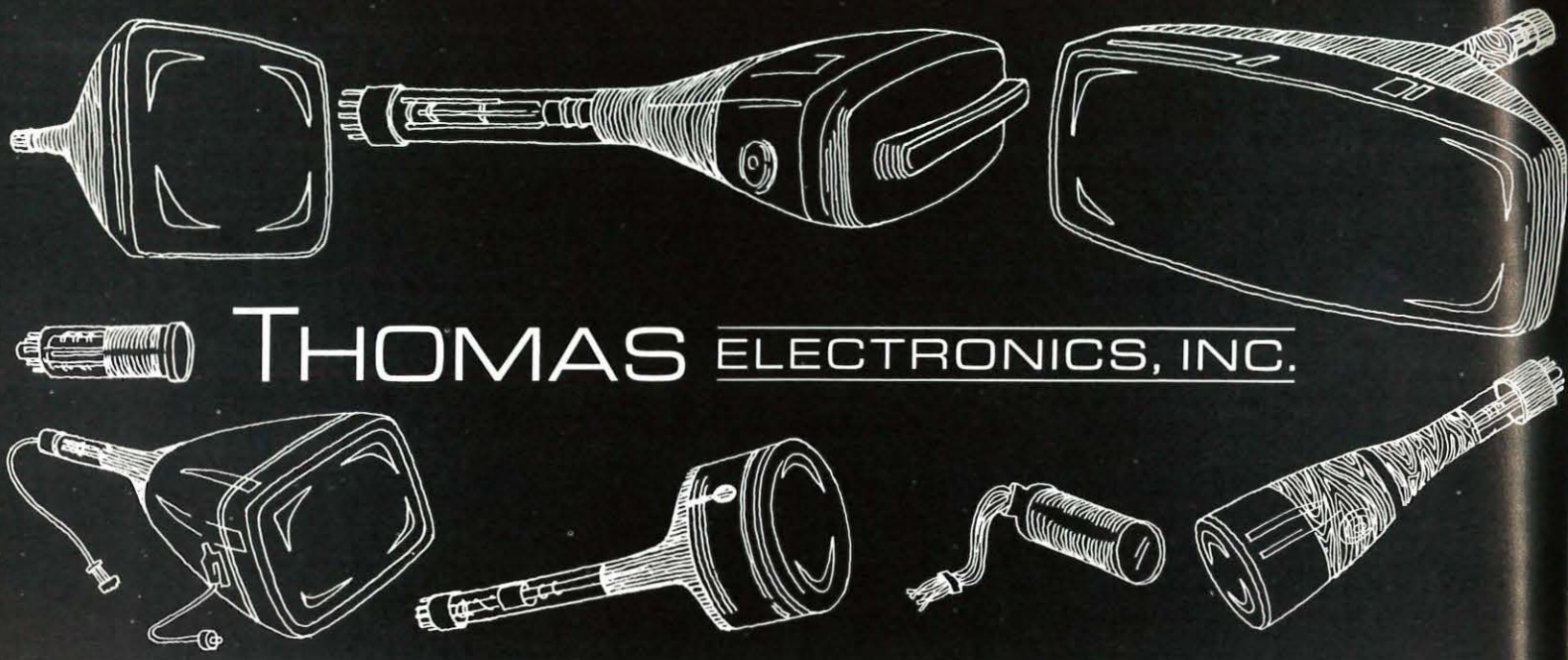

THOMAS ELECTRONICS, INC.

...best source for CRTS
for all commercial, industrial,
and military applications

- COMPUTER DISPLAY CONSOLES
- CHARACTER READERS & FILM SCANNERS
- DESK TOP CALCULATORS
- HEAD-UP, RADAR AND OTHER AVIONICS
DISPLAYS FOR SEVERE ENVIRONMENTS
- RESERVATION COUNTER TERMINALS
- HIGH RESOLUTION PHOTORECORDING
AND PHOTOCOMPOSITION SYSTEMS
- MEDICAL ELECTRONICS MONITORS
- PROJECTION AND SIMULATION SYSTEMS
- OSCILLOSCOPES & STUDIO EQUIPMENT
- AIR TRAFFIC CONTROL AND
GROUND SUPPORT DISPLAYS

Large modern production plant...fully equipped R&D laboratories...outstanding production, engineering and applications personnel...integrated support both for short-term and long-term programs...professional owner-managed, independent company...write or call...we promise fast reaction to your inquiry...

THOMAS ELECTRONICS, INC.

110 RIVERVIEW DRIVE, WAYNE, N. J. 07470 / Telephone: 201-696-5200 / TWX: 710-988-5836 / Cable: TOMTRONICS

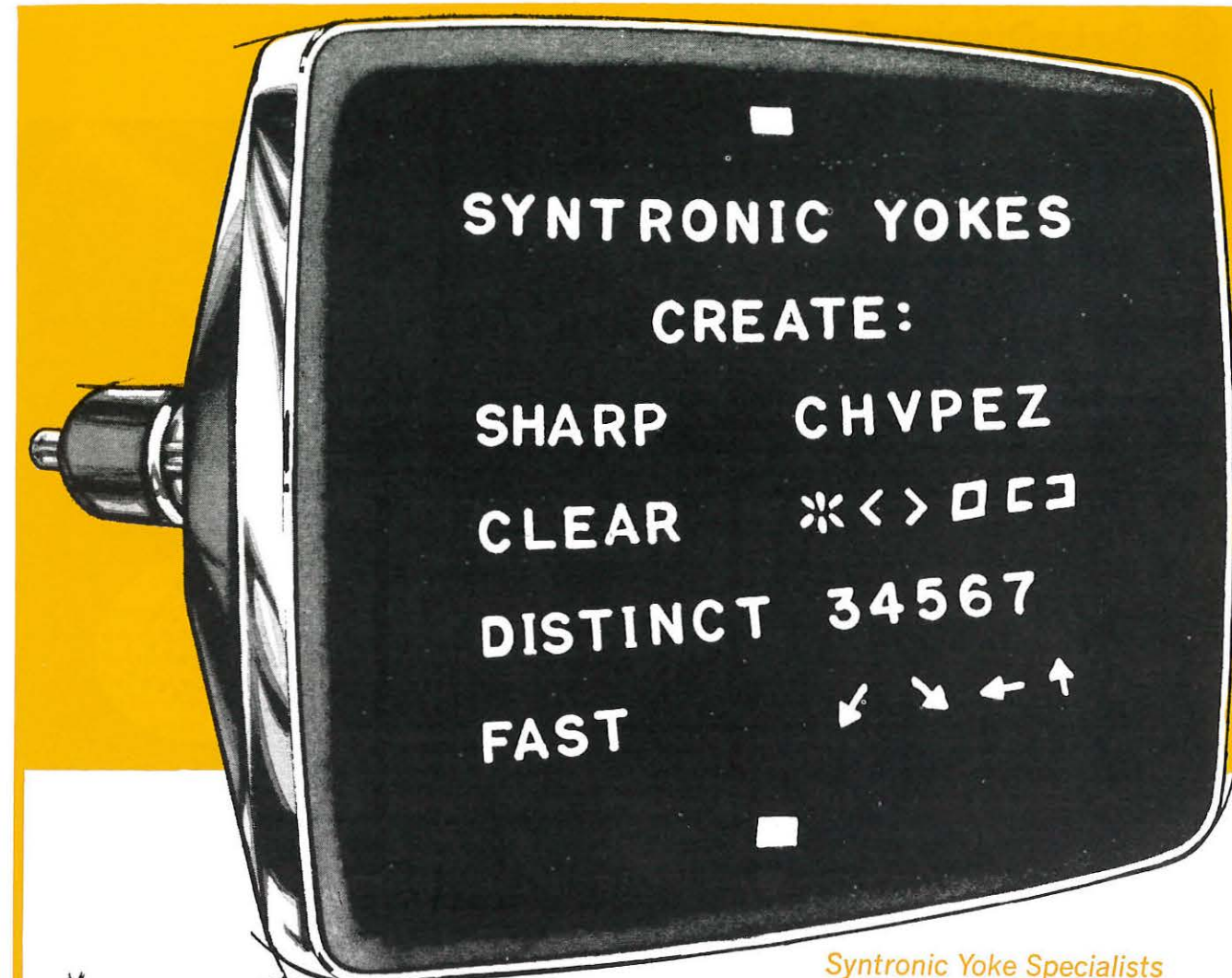

Syntronic Yoke Specialists

- provide a complete line of ● positioning deflection yokes
- high frequency character yokes ● beam centering coils
- anti-pincushion devices ● focus coils
- for all types of information displays used throughout the world.



From standard continuous line scan data displays to very special high speed random character displays... Syntronic's staff of yoke specialists assists engineers in designing, specifying and procuring the right yoke or yokes for maximum results.

An important "PLUS" is Syntronic's Production Capability. It backs up Syntronic's experienced engineering and design services. This is vital to the engineer who eventually needs yokes in production quantities.

Call Syntronic Yoke Specialists today for help with the design and production of your yokes.

syntronic INSTRUMENTS, INC.
100 Industrial Road, Addison, Ill. (20 miles west of Chicago), Phone (Area 312) 543-6444
Specialists in Components and Equipment used with Cathode Ray Tubes



Data Display Devices from Raytheon

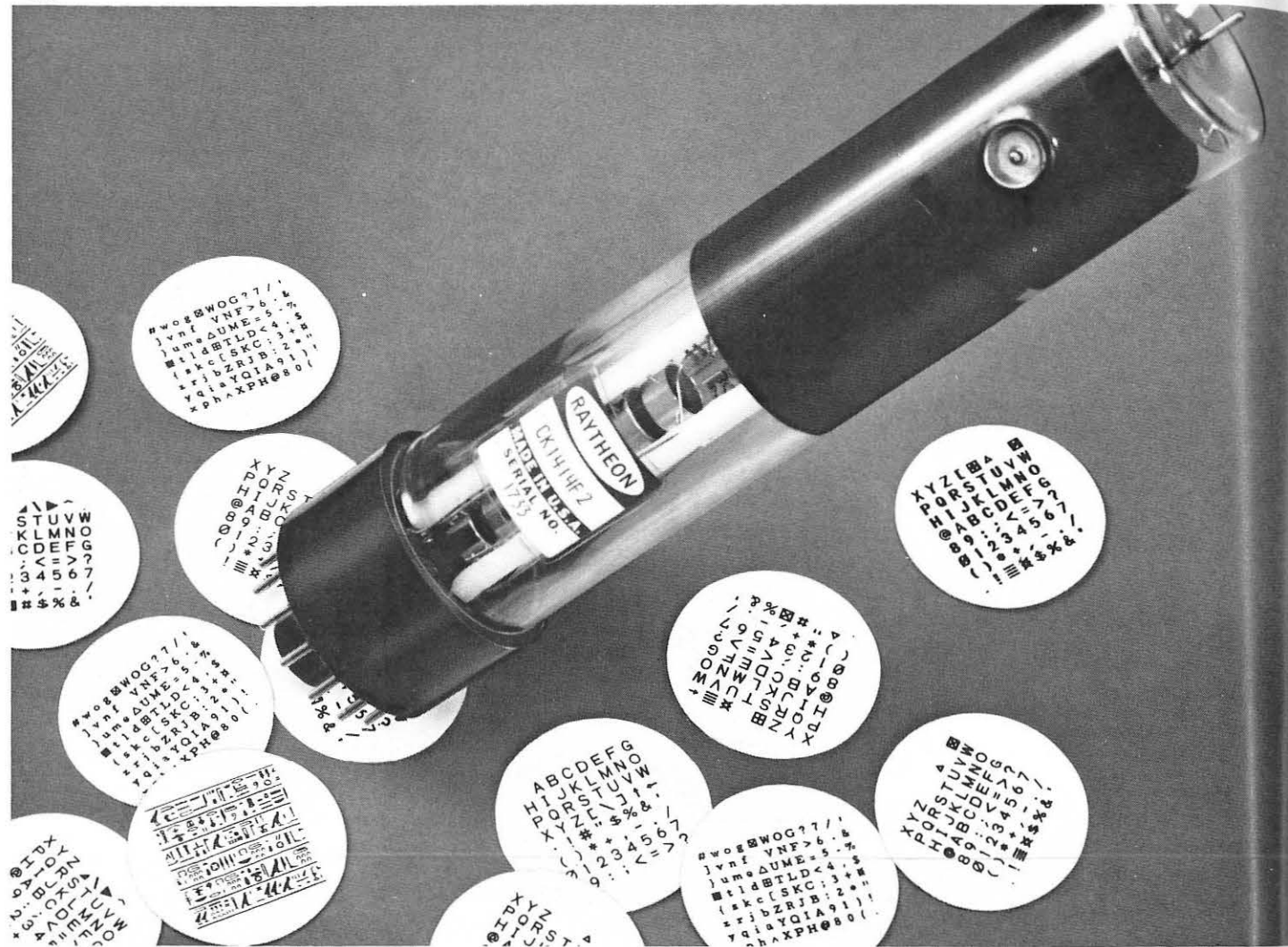

A Symbolray* monoscope can generate almost any presentation you can think of. (Hieroglyphics, anyone?)

With a Raytheon Symbolray, you can meet almost any data display requirement for different characters and/or symbols—ranging from standard ASCII† to custom data displays and even hieroglyphics. And we can meet the requirements with only an inexpensive change in the target font design.

An economical method of generating characters. The Symbolray monoscope provides a much more economical method of generating displays than using circuit cards. Only 2" by 12", it costs less than \$100 in quantities of 1,000.

The output of the Symbolray is obtained by electrically deflect-

ing the electron beam to the desired characters on the targets. The characters are scanned sequentially with a small TV raster. The display cathode-ray tube, on which the output is viewed, is scanned in synchronism. The monoscope uses electrostatic deflection and focus.

Full messages can be displayed—as shown at right—when the Symbolray method is used with buffer memory techniques. The monoscope is currently available with 64 and 96 character matrices.

Raytheon Dataray* CRTs include screen sizes from 7" to 24". Electrostatic, magnetic and com-

bination deflection types are available for writing alphanumeric characters while raster scanning.

For Symbolray data—or a demonstration—call your Raytheon regional sales office. Or write: **Raytheon Company, Components Division, Quincy, Mass. 02169.**

†American Standard Code for Information Interchange.

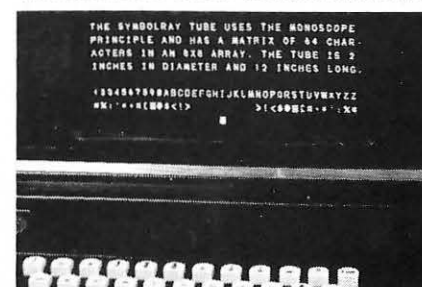

New Raytheon Projectoray* Tube produces more than double the light output of standard projection-type cathode ray tubes. The tube's output results in a light level of 15-foot lamberts on a 3' x 4' lenticular screen. Expected minimum operating life is 500 hours, 20 times the life of a standard projection tube.

The Projectoray's high light output and long life are due to its novel design. The design incorporates liquid cooling of the phosphor backplate. This allows the phosphor to be energized with a very intense electron beam. At high beam levels, very high peak light output is obtained. The light image is projected through a 5" optical window in the face of the tube. The electron gun is set at an angle to the phosphor and the deflection system compensates for keystone effects.

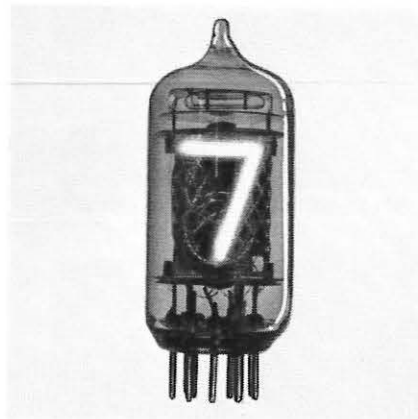

Datavue* Side-View Tubes. New Type CK8650, with numerals close to the front, permits wide-angle viewing. These side-view, in-line visual readout tubes display single numerals 0 through 9 or pre-selected symbols such as + and - signs. Their 5/8"-high characters are easily read from a distance of 30 feet. Less than \$5 each in 500 lots, they also cost less to use because the bezel and filter assembly can be eliminated and because their mating sockets are inexpensive. Many end-view types of Datavue tubes are also available.

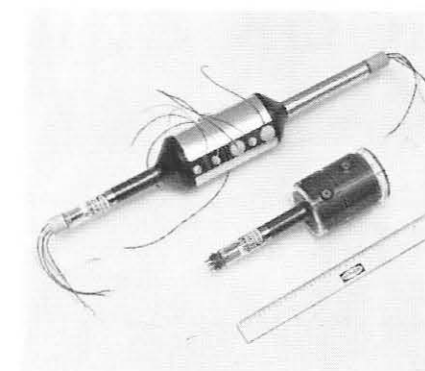

Recording Storage Tubes. The two new designs shown utilize miniaturized guns and necks to provide high deflection and focus sensitivity, resulting in savings in coil and power supply weight and size. They provide Kiloline resolution, long storage and fast erase capability. The single-gun version is Type CK1537 and the dual-gun version is Type CK1535.

Raytheon's complete line of electrical-output storage tubes feature high resolution and non-destructive reading. Information can be written and stored by sequential techniques or by random-access writing. Complete, gradual or selective erasure is possible.

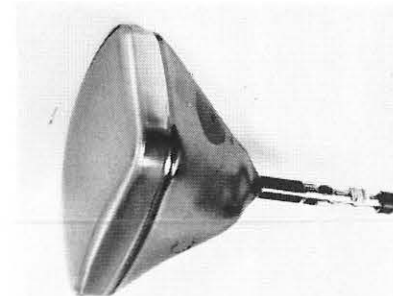

Dataray* Cathode Ray Tubes. Raytheon makes a wide range of industrial CRTs—including special types—in screen sizes from 7" to 24". Electrostatic, magnetic, and combination deflection types are available for writing alphanumeric characters while raster scanning. All standard phosphors are available and specific design requirements can be met. Combination deflection or "diddle plate" types include CK1395P (24" rectangular tube), CK1400P (21" rectangular), and CK1406P (17" rectangular).

For literature, call your Raytheon regional sales office. Or write to **Raytheon Company, Components Division, Quincy, Mass. 02169.**

*Trademark of Raytheon Company



Industrial Components Operation—A single source for Circuit Modules/Control Knobs/Display Devices/Filters/Hybrid Thick-Film Circuits/Industrial Tubes/Optoelectronic Devices/Panel Hardware

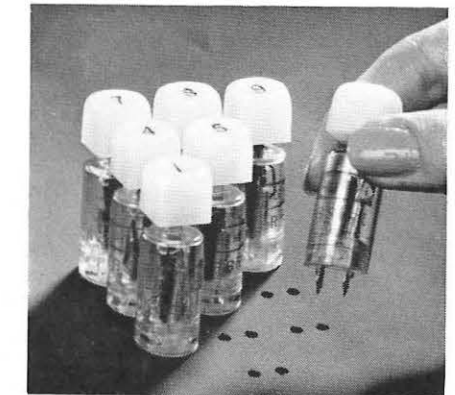

New Keyboard Switches. These keyboard switches—an original Raytheon design—are low cost yet extremely reliable. They are ideal for computer input/output devices, learning and business machines, and other advanced information and control equipment.

Just a featherlight (2 1/2-oz.) touch activates the switch, providing momentary contact at a current rating of 0.25A, 32V.d.c. Life expectancy of the dry reed type is more than 100 million cycles. Bounce is less than 250 microseconds. Yet, these switches cost less than \$1 in production quantities.

The contact pins snap into 0.125" PC board, locking the switch firmly in place for automatic flow soldering—thereby reducing assembly time and costs.

All switches are made of high-quality materials: polycarbonate plastic, stainless steel, beryllium, copper and noble metals. Bases can be flat or sloped to a 10° angle.

The switches are available with a variety of standard and custom cap shapes, sizes, colors and alphanumeric. Caps are hot die stamped, cured and backed with epoxy coating to provide wear resistance and reduce glare.

Raytheon key switches are available in single- and double-level dry reed types and in single- and double-level wipe-action types.

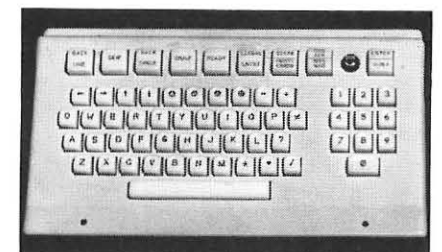

Complete, custom-made keyboards—using the switches described above—are also available from Raytheon. These keyboards can be designed, built and shipped to you in minimum lead time. All assemblies are supplied with alphanumeric, symbols and coding to your specifications. They are also available with data lines, electronic interlock, connector to external power sources, and with or without case.

90-second look at IEE's wonderful world of readouts

Readouts are our special craft. Using any characters you want. Any colors or color combinations. Any input, BCD or decimal. Any input signal level. Any mounting, vertical or horizontal. Five sizes,

up to 3 3/8". Many configurations, options and accessories. Long lamp life (to 100,000 hours; up to 175,000 hours at reduced voltage). If it doesn't exist and you need it, we'll build it.

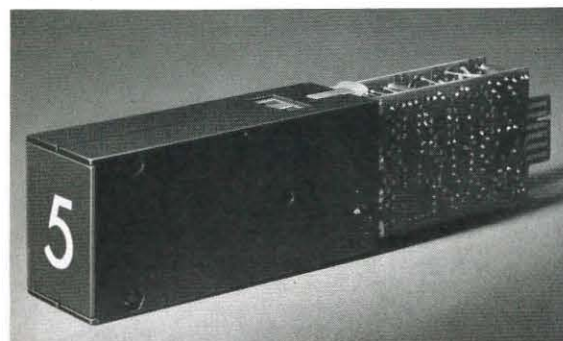

10H—World's most popular readout. And we've improved it. Double condensing lens provides exceptional character brightness. Greater clarity at wider angles and longer distances, even under high ambient light. .937" sq. viewing area. Mil-spec version available.



160H—Exceptionally large viewing area (1.56"H x 1.12"W) for overall size. 45 FL character brightness with a 6.3V \$.20 lamp. Displays messages simultaneously with symbols.



80—Large screen unit suited for annunciator applications such as factory call systems and production control. 3 3/8" character height can easily be read at 100'. 160° viewing angle.

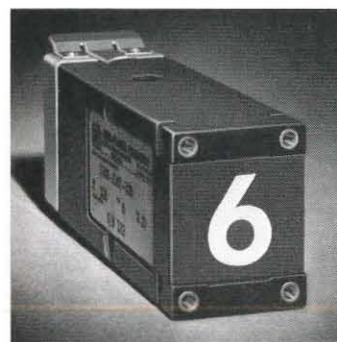

120H—Miniature rear-projection readout (.62" sq. screen) easily read from 30' under high ambient light. Quick-disconnect lamp assembly speeds lamp replacement.

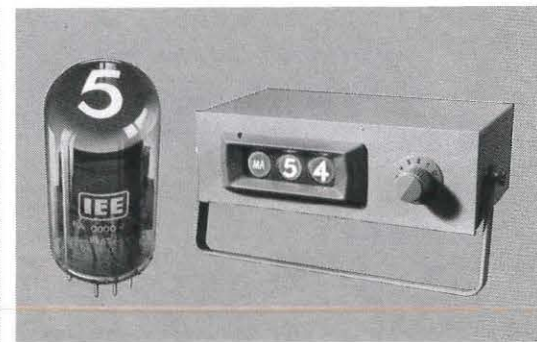

nimo™—First 10-gun CRT single-plane display. Projects numbers, letters and words onto a fluorescent screen. No image ambiguity. No external focusing required. No ambient light worries. Exceptionally wide viewing angle. Ideal for instrument application.



875—Miniature 24-position readout assembly with a cost per display of only \$1.45 each. .620 sq. in. viewing area with overall case size of 1.39"H x .90"W x 3.095"D. Exceptional brightness, clarity. Front panel access.

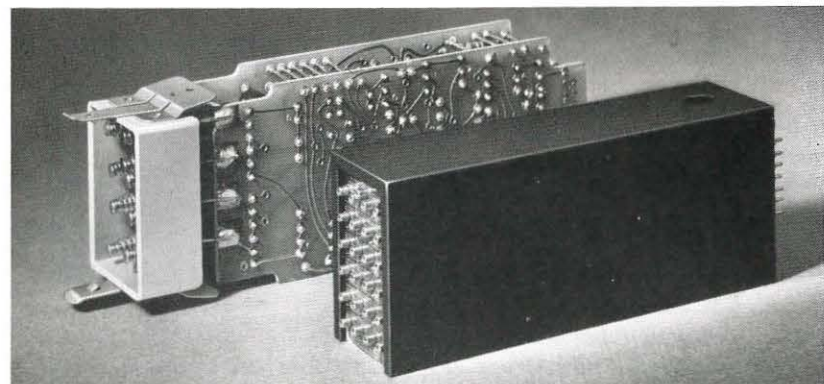

IC Driver/Decoders—Small, reliable units for driving IEE readout incandescent lamps ranging from 250 ma @ 6V to 40 ma @ 28V. Fully compatible with modern IC's. Accept a variety of binary codes for decimal conversion. Require normal signal V., draw less than 2 ma per data input. Internal data storage for pulsed oper.

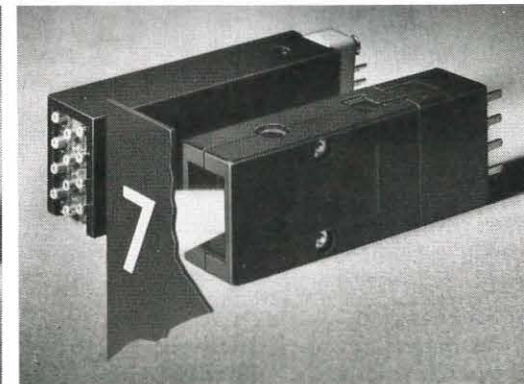

345—IEE's smallest rear-projection readout. Viewing area .38"H x .34"W. Based lamps. Low cost. Individual readouts plug into perm. wired housing for quick message change. Easy front panel access.

Industrial Electronic Engineers, Inc.



7720 Leona Ave., Van Nuys, California

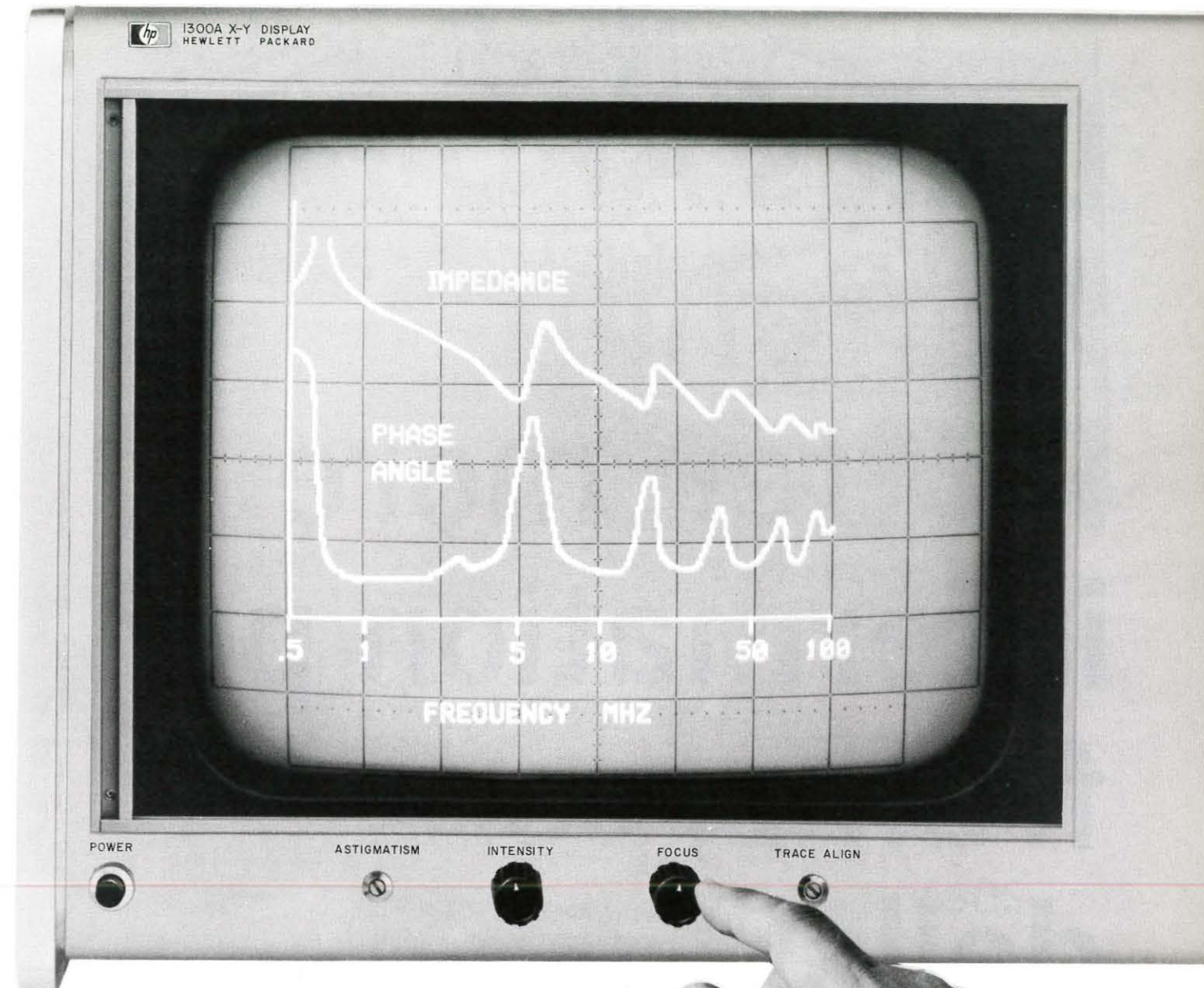

NOW YOU CAN MATCH A MONITOR TO YOUR COMPUTER'S SPEED

Extraordinarily wide dc to 20 MHz bandwidth on all three axes of the hp 1300A X-Y Monitor gives you fast writing to display your alphanumeric and graphic computer readouts accurately—using a minimum of your computer's time. An internal graticule, 8 x 10-inch screen lets you see a big, sharp picture you can read across a brightly lighted room—without parallax error.

The electrostatically deflected beam in the 20 kV CRT, gives you bright, easy-to-read displays—even when observing low rep-rate signals. Standard sensitivity is 100 mV/in.

The hp 1300A is an inexpensive (\$1900) monitor, ideal for your computer applications. Its large screen CRT and all solid-state circuitry require only 175 watts and is packaged in a compact, 12" high cabinet weighing 47 pounds, including self-contained power supply.

Get the full details on the hp 1300A X-Y Monitor from your hp field engineer—he can help you select phosphors, filters and graticule options to match the monitor to your application. Or, write to Hewlett-Packard, Palo Alto, California 94304. Europe: 54 Route des Acacias, Geneva.

HEWLETT  PACKARD

OSCILLOSCOPE SYSTEMS

Link's APD-5000 Microfilm Plotter, more information per frame, per dollar.

The Link APD-5000 Microfilm Plotter has a 4096 x 4096 resolution that allows the recording of more information per frame.

Computer-generated information is recorded at 100,000 points per second with variable line widths. Both whole value and incremental plotting are a part of the plotter's operation. The comparatively low purchase price includes a third generation hardware unit with third generation software.

For details, write: Advanced Technology Sales, Department F, Link Group, 1077 East Arques Avenue, Sunnyvale, California 94086, or phone (408) 732-3800.

LINK GROUP
**GENERAL
PRECISION
SYSTEMS INC.**

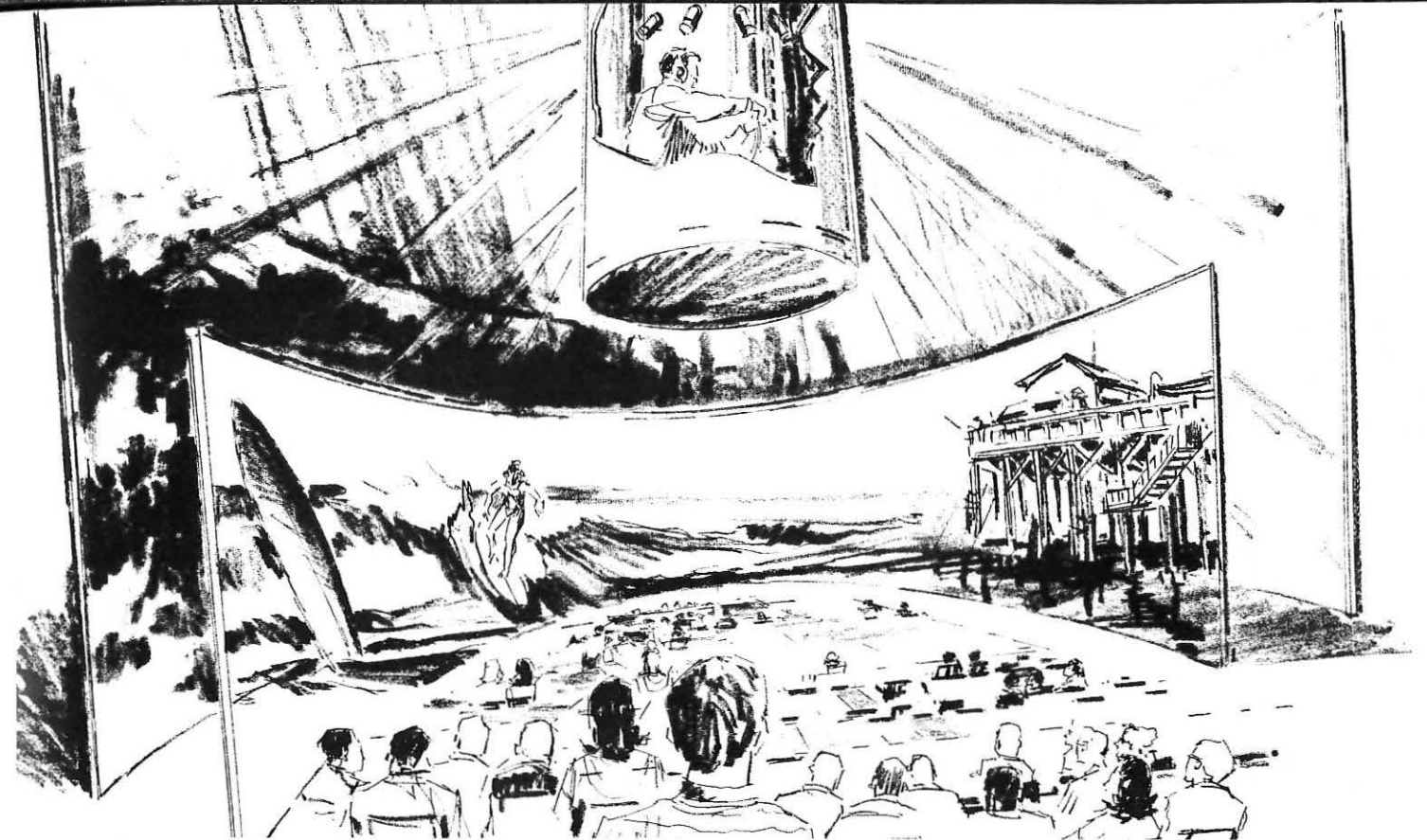

Artist's drawing depicts the proposed theatre that will display the new 3-D picture.

True stereoscopic movie system without glasses

by ROBERT B. COLLENDER

In the previous issue (July/August, 1968) of this journal, in which the first part of this paper was presented, a brief discussion was presented on the problems involved with adapting grand-scale holography to the movie theatres. A discussion was presented which led to the conclusion that three dimensional reproduction should be on a unity magnification basis (e.g. the size of objects in the scene captured should be equal to the size of reconstructed images in the wide screen stereoscopic theatre).

Gabriel Lippman's lenticular system was shown expanded to its possible application to future theatres and the resultant problems associated with this adaptation were discussed.

The author's concept was described in which the capture equipment consists of a 100 foot arc of 1500 pinholes which are uncovered sequentially to expose ten sets of horizontally-moving spherical lenticular filmstrips. The filmstrip's movement and exposure are synchronized by a central control system. The resultant film is specially processed for centralized projection. In the proposed new 3-D theatre, a centralized projection booth is at the center of curvature of a cylindrical screen and stationary electronically controlled Kerr cell-shutter selector. The pictures are released to the screen in a cyclic scanning time-multiplexed sequential overlap fashion as they rapidly

sweep over the semi-specularly reflective screen. In step with this sweeping myriad of pictures, an electronically operating shutter system, some 50 feet in front of the screen, forces each eye in the theatre to see the appropriate perspective for its particular position. Because of this, each person in the theatre sees a "different view" of the scene in true stereoscopic vision. The audience will see the scene reproduced as through a large bay window (100 feet wide and 50 feet high).

In the last issue, an introduction to the theory of the system was given. The image dissection process was described. The mathematical formulas were developed for predicting the vertical shrink-expand factors for each spatial image depending on its location with respect to the projection geometry and any given observer position. A scale schematic drawing of the proposed theatre was presented. A brief description of the camera system was given along with a brief introduction to its theory of operation.

In the following concluding publication (part 2) of this paper, the camera system is continued—followed by the central processor, the projection system, the electronic shutter selection system and screen illumination calculations.

MECHANICAL CONFIGURATION OF CELL

Fig. 28 shows a typical cell plan view with its feed and take up reels and continuously moving vernier exposure belt requiring about 3 transverse slits between adjacent pinholes so that it can move at a slow pace to avoid prolonged wear and serve to control sequential exposure of the pinholes.

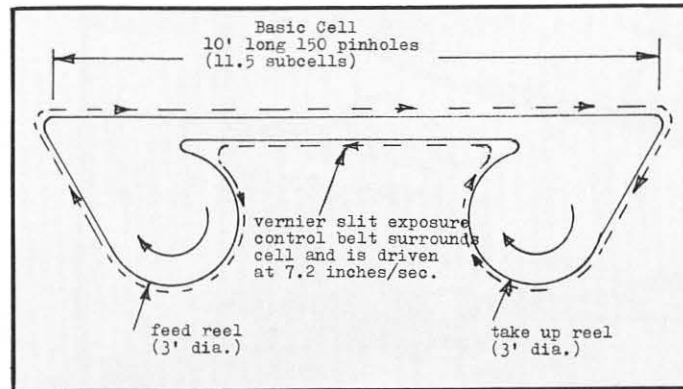

FIGURE 28: Cell mechanical features

The optimum size pinhole can be found from the following formula^(9,10): This formula considers blur due to diffraction and interference effects at small aperture sizes and a blurred image due to too large an aperture. $D = \sqrt{0.00007v}$; where v = pinhole to film distance (inches) and D = optimum pinhole diameter (inches). For the required 1.45 inch focal length, $D = 0.01$ inch. This aperture could be made 10 times this size as projection of 0.1 inch aperture on the film behind a lecticle element does not take up any more than 1/13th of 80% of the element diameter. Also this type of film does not behave the same as standard film in that a larger diameter aperture does not tend to blur the image formed. The smaller pinhole diameter was selected because for a fixed required exposure time, the vernier belt speed is reduced by a factor of 10.

VERNIER SLIT-SHUTTER BELT REQUIREMENTS

In the next section, the exposure time will be shown to be 1/360 second. With a minimum width of transverse slits on the vernier belt of 0.01 inch (equal to the diameter of the pinhole) the minimum belt velocity equals $0.02 \text{ inch} \div 1/360 \text{ second} = 7.2 \text{ inch/sec}$. The slit shutter must move twice the pinhole diameter during the required exposure time.

The vernier slit belt must be designed such that pinholes 40 degrees apart on the 120 degree capture arc (measured

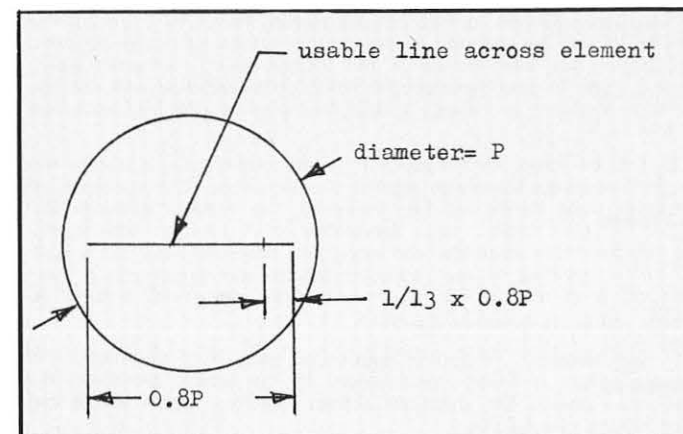

FIGURE 29: Usable space on emulsion behind lenticular element

from the imaginary center of the 100 ft. arc) are opened together and progress (say to the right) together. When the last pinhole on the right of the 120 degree arc of pinholes is opened, then immediately thereafter the first pinhole on the left of the 120 degree arc is opened to maintain the 40 degree spacing. This synchronism is accomplished by the central power and sync station which controls all 10 cells during the capture of the scene.

CAMERA PINHOLE REQUIRED EXPOSURE TIME

The maximum allowable pinhole exposure time (or "on" time) must be such that the information written behind an element, for a particular pinhole, does not move into the area to be occupied by the pinhole on the same elevation and separated by one sub-cell (see Fig. 29).

In Figure 29, "P" is the pitch of elements (from the section on Image Dissection Photography, "P" was set at 1/15 mm). Therefore, $860 P = W = 2.25 \text{ inch}$ (the 70 mm usable film width).

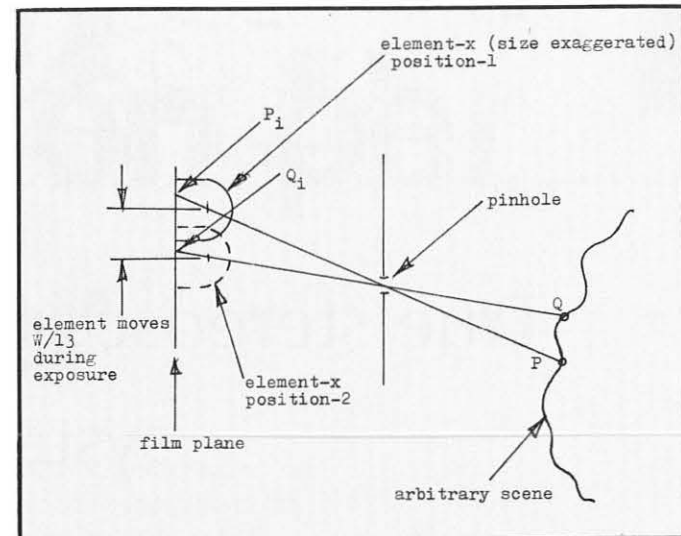

FIGURE 30: Effect of film motion during exposure time

To assure no overlap of information behind a given element, the film must not move more than $W/13$ during the open time of any given pinhole. Therefore, the allowable exposure time of any pinhole = $W/13 \div 64 \text{ inches/sec} = t$ (where 64 inches/sec = velocity of film through the cell). From this, the exposure time is found equal to 1/360 second.

The wiping action of any given element over a distance $W/13$ does not in any way tend to prepare the film for a blur during playback. From Figure 30, it can be seen that P is recorded at P_i and Q at Q_i in the same element, as the film moves past the pinhole. This system operates in the same fashion that when a line is determined by two points, a third point can only align with the other two at the time when all three are on the same straight line. An example of this is: P_i , the node of element -X at position -1 and the pinhole would then release "P" to the screen. Likewise, Q_i , the node of element -X at position -2 and the pinhole would release "Q" to the screen.

CALCULATION OF THE NOMINAL QUANTITY OF COMPLETE IMAGES/FRAME

A primary resolution in the matrix of elements (or spheri-

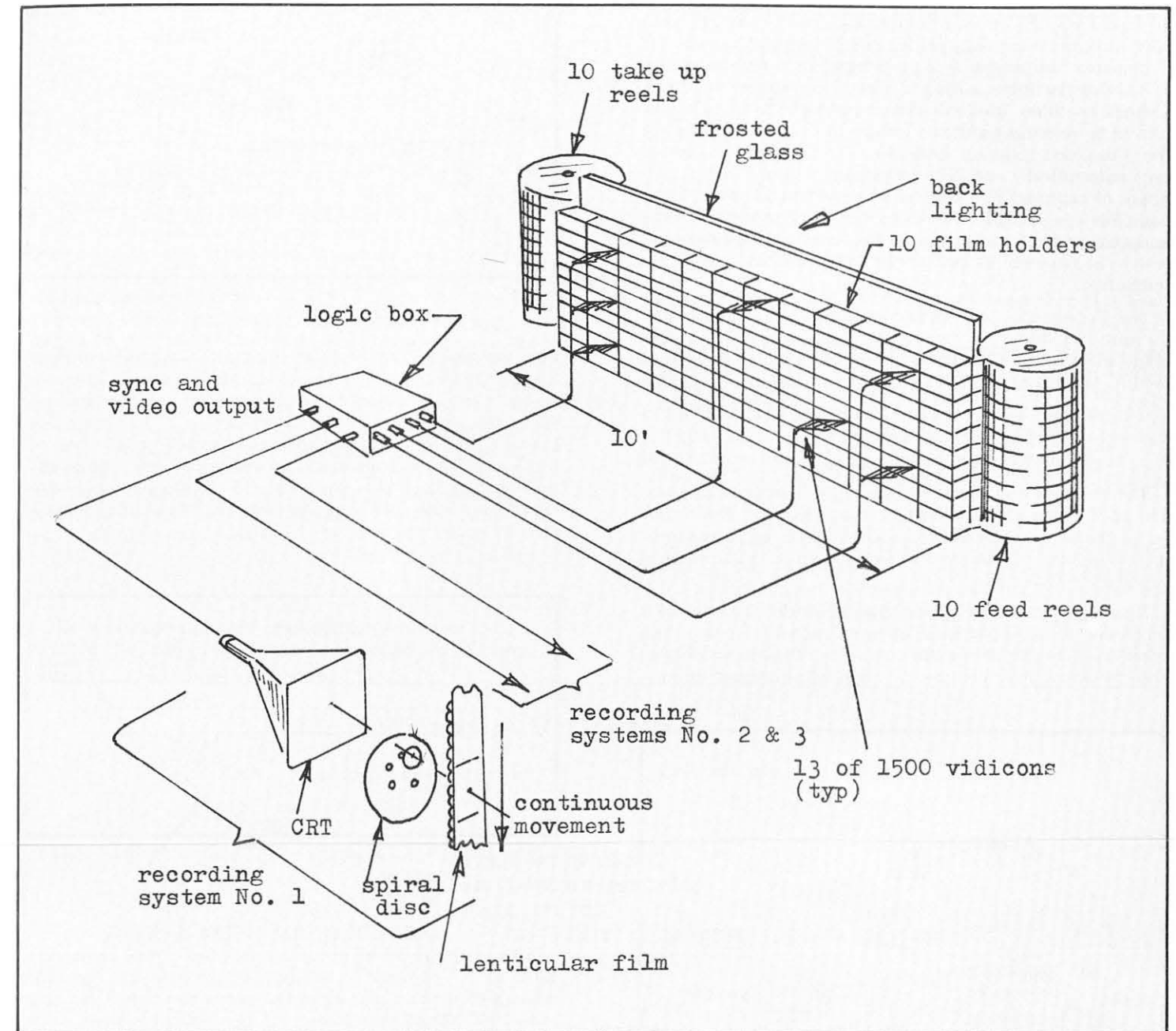

FIGURE 31: Essentials of central processor

cal lenticules) has been set at 15 per millimeter and a 2.25 inch square frame is shown to have 860 by 860 primary frame elements (that number is available to be projected to the screen at any time). The maximum number of images that can be registered on a 2.25 x 2.25 frame can be calculated if the primary film resolution is known. This resolution can be taken at 336 lines/mm (a typical film resolution used in image dissection photography). The number of picture elements across the lenslet = $80\% \times 336 \text{ lines/mm} \div 15 \text{ elements/mm} = 18 \text{ lines/element}$. Therefore; $(18)^2$ equals approx. 320 pictures/frame.

In the processor and projection system, 320 pictures per frame has been selected in order to maximize film utility—but the $(13)^2$ quantity chosen for the capture system is within these limits and was a compromise on the length of a cell. The cell length for an $(18)^2$ system would be about 22 feet and unwieldy to manage.

THE CENTRAL PROCESSOR

The intermediate step between the capture and playback systems (not including normal development procedures) is the central processor.

The central processor is required to accept 10 film-strips with 1500 "effective" camera locations spread out over a 100 foot arc length, and convert them to 3 film strips which can sweep the sequential pictures onto the curved screen from a central location (the cylinder axis of the screen) and the selector slits high over the heads of the audience.

Although the system proposed seems quite expensive at first, it represents a one-time expense, and is used under laboratory conditions where maintenance procedures are more readily attended to.

Figure 31 shows a simplified conceptual drawing of the proposed central processor. The 10 films from the capture systems are first developed to negatives and inserted in the

10 feed reels, the 10 film holders and the 10 take-up reels. 1500 vidicons using pinholes for objective lenses receive the illuminated film images in a pre-programmed fashion (determined by the logic box) and direct the images to the 3 cathode ray tubes. Image dissection photography is again employed to re-photograph the images in proper sequence on the 3 resultant spherical lenticular film strips. All equipment runs automatically and in a continuous fashion, so that 1½ hours of captured film can be processed in 25 days (if the equipment is run 24 hours/day). This long processing time is paced by the framing rate of the closed television system which is assumed to run at the conventional rate of 30 frames/sec.

The 3 continuous and completely filled (18)² pictures/frame 70 mm film strips, are developed to positives and are then ready for projection by the 3 groups of (3 lenses each) projectors, using a common central Xenon short arc projection lamp.

PROJECTION SYSTEM

The three 70 mm film strips each use 3 projection lenses and all 9 lenses share the same projection lamp. The 9 projector lenses are arranged in a circle, with each lens projecting pictures 40 degrees displaced from an adjacent lens, as shown in Figure 32.

Figure 33 shows a simplified drawing of the 3 groups of 3 projection lenses each with its feed and take up reel. The numbers 1 thru 9 indicate the numbers of the projection lens and the arrow indicates the direction of projection through

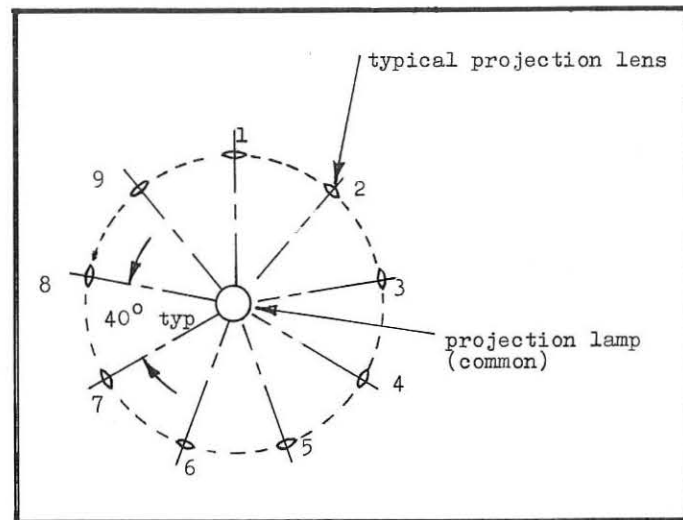

FIGURE 32: Radial projection system

the film. An adequate service loop is provided between the 3 projection lenses.

Since one strip of film with only one track of picture data is serving 3 lenses, care must be taken that each of the 3 lenses only projects that portion of the film intended for it. To assure this, a plan view of the film strip in Figure 34 shows how the 120 degree film section for each lens is separated by 240 degrees of film space which is devoted to the remaining 2 lenses in that group. The adjacent identical number strips (corresponding to a given projection lens) are always projected in sequence. For example, after film section -1 passes by projection lens No. 1, and was projected to the screen, sections 2 and 3 pass through while the number -1 lens rotates through 240 degrees (while not projecting) and

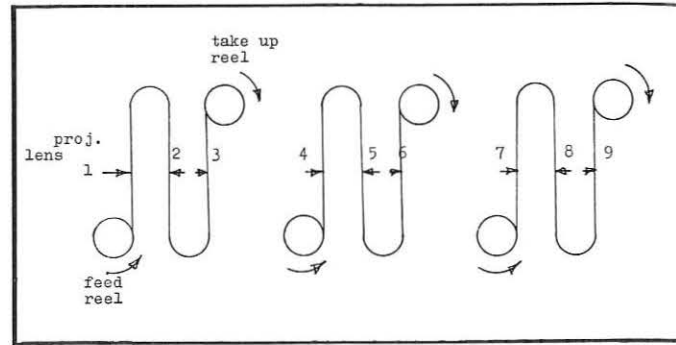

FIGURE 33: 3 groups of 3 projection lenses for 9-facet projection system

then the next section -1 passes by the No. 1 projection lens for the 120 degree sweep in projection. The service loop can be made any convenient length to accommodate the required 40 degree spacing of the 2 adjacent lenses in the group. For example, the No. 2 projection lens may pick up any one of the No. 2 film-sections if the processor had been programmed to play back that particular No. 2 film section in the next time frame following the previous No. 1 film section scan by projection lens No. 1.

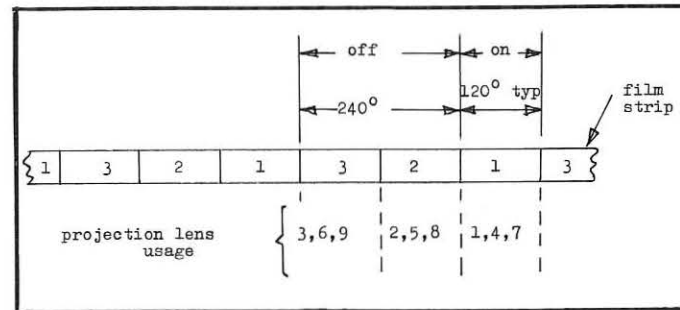

FIGURE 34: Plan view of projection film strip (on-OFF times refer to film section 1)

PROJECTION FILM LINEAR RATE

Nine projector lenses revolve about the central projection point at 2.7 rev/sec. To satisfy 1500 pictures/lens per 120 degrees of rotation, the individual projection lens frame rate equals 12,000 frames/second for the 9-facet system. Each frame of the 70 mm film is 2.25 inches usable square format and each of these frames contains approximately 320 individual image-dissected images. The film velocity is calculated as (12000 images/sec ÷ 320 images/frame) (2.25 inches/frame) or 7 feet/second. This means that the film section length (for 120°) for any given projector lens, is about 10 inches.

TOTAL FILM CONSUMPTION FOR A 1½ HOUR MOVIE FOR BOTH CAPTURE AND PLAYBACK COMPARISON

Capture film usage = 10 films x 5 ft/sec x 1.5 hour x 3600 seconds/hour equals 270,000 feet of film (total)

Projection film usage = 3 films x 7ft/sec x 1.5 hour x 3600 seconds/hour equals 113,000 feet of film (total)

In capture: 11.5 x 13 = 150 images per frame were utilized.

In projection: 320 images per frame were utilized.

$$113,000 \div 270,000 = 0.425$$

$$150 \div 320 = 0.47$$

From these two ratios, it can be seen that efficient film usage has been closely observed.

PROJECTION LENS FOCAL LENGTH AND KEYSTONE PROJECTION PROBLEM

From Figure 20, the average projection distance is given at 133 feet and the screen height is given at 69 feet. Based on these facts, the projection lens focal length, for a 70mm format, is 4.35 inches. This value must also be employed in the central processor recording system in order that the recorded film will be compatible for projection within the required geometry.

The projection lens must be corrected for "keystone" projection so that the picture on the screen appears as a square when viewed normally to the screen. The processor-lens will not introduce any keystone effects. The reason for not utilizing the cathode ray tube keystone scan circuits to photographically process the wedge shaped picture so that no corrector would be needed at the projection station, is simply that the resolution over the recorded frame would then not be uniform. By using keystone correction at the projection station, uniform resolution over the entire projected picture is maintained.

PROJECTION LENS f/NUMBER

The maximum diameter of the aperture in the spiral disc required for playback of the image-dissected pictures is

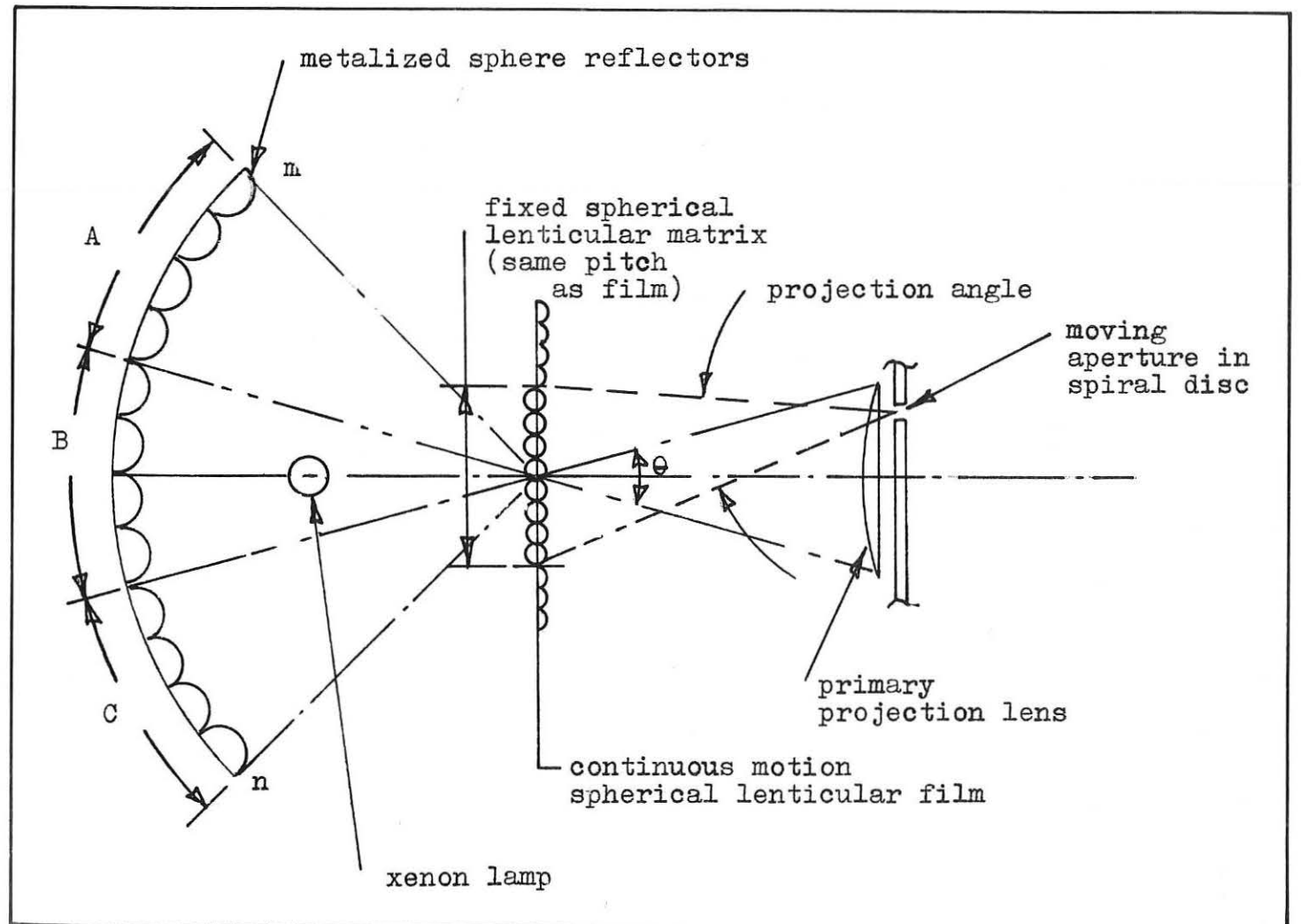

FIGURE 36: Elevation view of projection

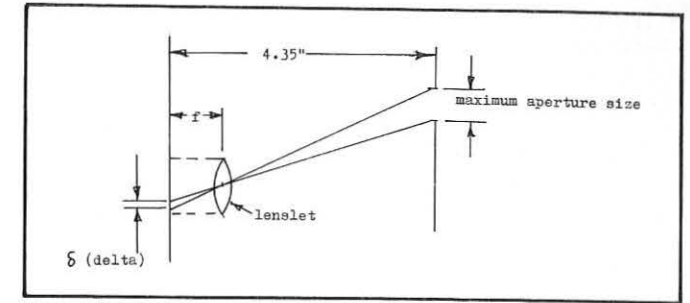

FIGURE 35: Projection lens f-number determination

calculated to be 0.097 inches from its image size in a lenticular element as shown in Figure 35.

The focal length of the spherical lenticule is calculated at 0.133 mm from the 15 elements/mm factor and the chosen f-2 value. "Delta" is shown as the image size on the film, of the maximum sized aperture in the spiral disc. The aperture must be small enough that the value of "delta" does not occupy more than 1/18th of the lenticule diameter.

The projection lens f/number is then 4.35/.097 = 45.

OBSERVER'S VIEWING ACUITY

Acuity is defined as the reciprocal of minutes of arc subtended at the observer's eye by two closely spaced points which are on the threshold of being resolved. It is known for example, that a person with 20/20 vision sees with an acuity of unity and the included angle is 1 minute of arc. A 20/40 person has an acuity of ½ and sees 2 minutes of arc, etc.

The 69 foot high screen will be divided into 860 horizontal lines or a separation of 0.96 inches for 70mm film. This corresponds to 1.8 min. of arc for the far observer and 4.4 min. of arc for the near observer.

If 5 inch film were used, the number of horizontal lines would double and the resolution would improve by a factor of 2 or 0.9 minutes and 2.2 minutes, respectively. Unfortunately, the film speed doubles in the capture and playback. It is also possible to double the primary film resolution which would allow the total quantity of spherical lenticular elements in a frame-matrix to quadruple. This is no doubt the best approach to take in order to keep the film speed down.

PROJECTOR CONCEPT TO IMPROVE LIGHT OUTPUT

From figures 36 and 37, the metalized spherical reflectors have a pitch diameter such that segments A, B and C in the elevation view each contain 18 spheres included in angle θ . The surface m n p q is filled with spherical reflectors of this pitch-diameter. At the back of the film plane, a fixed refrac-

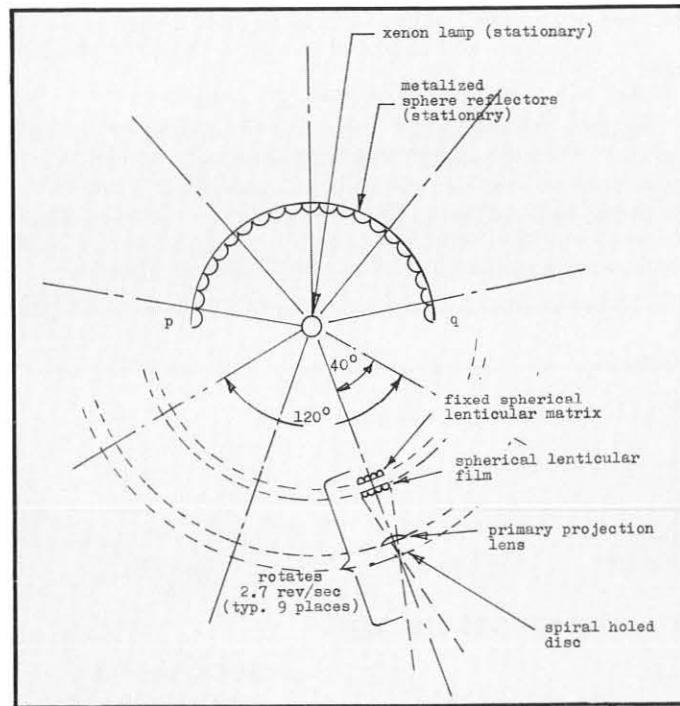

FIGURE 37: Plan view of projection

tive spherical lenticular matrix is placed, which has the same 15 elements per millimeter pitch as the film strip. The Xenon lamp's image will be formed in each of the spherical balls, and hence the m n p q surface becomes a myriad of extended point sources. The myriad of bright sources are imaged by the refractive fixed lenticular matrix such that 320 overlapping bright discs are inscribed onto the film-plane for each of the lenticular elements. This technique tends to maximize the utility of the bright Xenon lamp source and direct the light to the moving aperture regardless of its location in the main aperture of the primary projection lens.

ELECTRONICALLY CONTROLLED SHUTTERS BETWEEN AUDIENCE AND SCREEN

In Figure 11, an arc of vertical slits is shown between the audience and the screen extending between A_s and B_s. This arc length has been shown to be 104 feet and extending over a 120 degree circular arc of 50 ft. radius. This arc will contain 1500 electronically controlled slits of 0.83 inch width.

These parameters are derived from the theatre layout geometry and capture requirements mentioned earlier. The theory behind slit requirements can be found in the section

"General Principle of New Approach Using Central Projection Scan Techniques".

Because 40 degrees (or about 35 feet of arc) is scanned in 1/24th of a second and repeated with essentially no delay, the requirements are too stringent for any mechanical selection techniques, so the Kerr cell approach has been chosen.⁽¹¹⁾

The basic principle of the Kerr cell is shown in Figure 38. The light output of the cell is turned off with no voltage applied between cell-electrodes because of the presence of cross-polaroids as shown in the figure. When a high voltage is applied to the cell, the plane of polarization is rotated 90 degrees and about 30% of the incident light comes through the cell. These cells are known to respond in nano-seconds and are ideal for this intended selector-application.

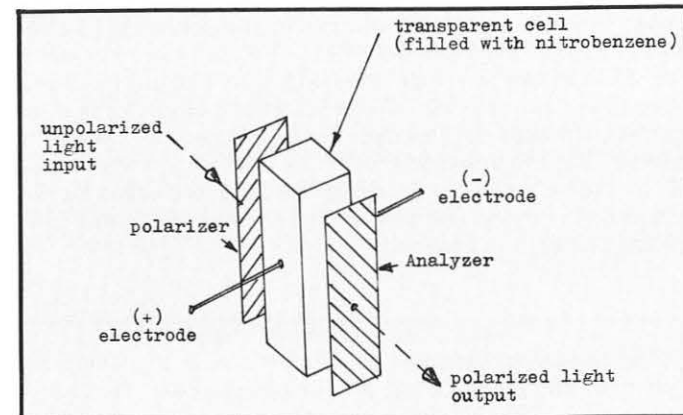

FIGURE 38: Basis of a Kerr Cell

The peak voltage for maximum transmission = $V = 300 d/\sqrt{2}K$ volts or KV = $33.5 d/Vl$.

Where $K = \text{Kerr constant} = 4 \times 10^{-5}$ and d and l the width and depth of the cell (see Fig. 39) are given in centimeters. For $l = d = 0.83$ inches, the required pulsing high voltage is 48 KV.

BREAKDOWN GRADIENT OF AIR⁽¹²⁾

An approximate rule for uniform fields at all frequencies up to at least 300 MHz is that the breakdown gradient of air is 30 peak KV/CM or 75 peak KV/inch at set level (760 mm of Hg) and temperature of 25°C.

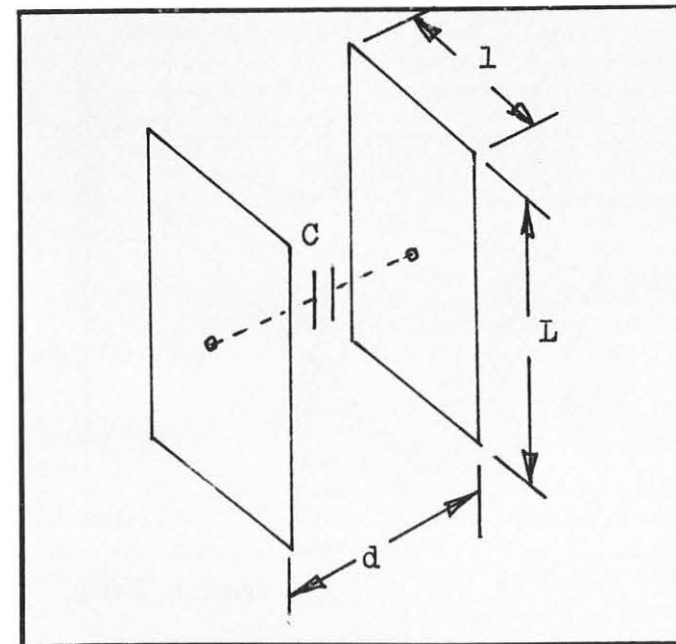

FIGURE 39: Geometry of Kerr Cell plates

The breakdown voltage is approximately proportional to pressure and inversely proportional to absolute K° temperature.

If this rule is applied, the breakdown in air for this system would not occur under normal conditions below about 62 KV for a gap width of 0.83 inches. For a large margin in factory of safety, the selection of 48 KV for the Kerr cell pulse voltage seems adequate. This would allow the temperature in the cell electrode vicinity to rise to 150°F and a pressure drop to 25 inches of Hg before an arcing of electrodes took place.

KERR CELL CAPACITANCE

"C", in Figure 39, is the cell capacitance which must be charged during each pulse of electrical energy.

Convenient lengths (L) for handling these cells would be about 4 feet.

Since $C = 3.18 Ll/d$, where C is given in micro-microfarads, for an l/d ratio of unity, $C = 387$ micro-microfarads.

KERR CELL APPARENT DEPTH DUE TO REFRACTION OF NITROBENZENE

An interesting effect results in using the cells which are filled with a liquid called nitrobenzene. Because of the refractive index of this solution ($n = 1.553$) the apparent cell depth is much more shallow than its actual depth. This fact allows observers sitting in the audience at some angle to the slit normal line, to see through the slit. Ideally the slit depth should be zero so that the appearance of vertical bars in the final picture is virtually eliminated. Figure 40 shows that the effect of the index of refraction is to decrease the cell depth. 38 degrees is the maximum angle imposed on any viewer.

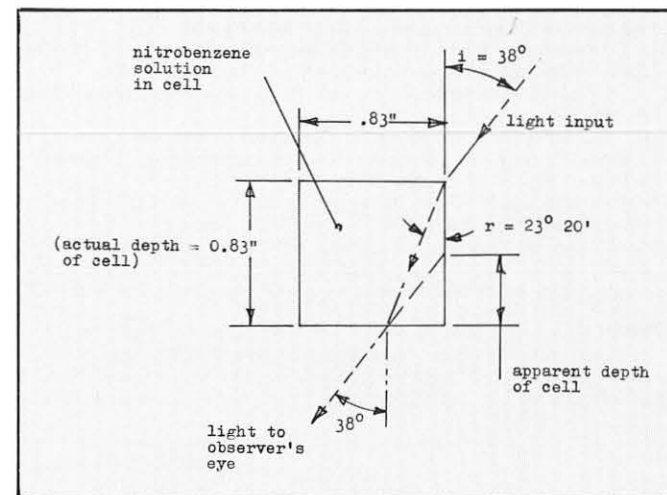

FIGURE 40: Apparent depth of Kerr Cell due to refractive index of nitrobenzene solution

DC RESISTANCE BETWEEN PLATES

$$R = \rho^d/Ll, \text{ where } \rho = \text{DC resistivity of nitrobenzene.}$$

$$\rho \text{ (none pure)} = 10^6 \text{ ohm-cm}$$

$$\rho \text{ (pure)} = 10^{10} \text{ ohm-cm}$$

In practice, it is difficult to attain better than 10^8 ohm-cm. This is achieved by distillation of the nitrobenzene.

$$R = 1 \text{ meg-ohm (for a clean cell)}$$

$$R_{\text{max}} = 100 \text{ meg-ohm. (In the following calculations for required driving power, etc., the practical value of } R = 1 \text{ meg-ohm will be used.)}$$

GENERATOR POWER REQUIRED TO CHARGE SLIT CAPACITY

$$E = CV^2/2 \text{ where } C = \text{Capacity in farads}$$

$V =$ voltage across plates and $E =$ joules (watt-seconds)
 $E/t =$ drive power in watts; where $t =$ the pulse width
 $t =$ duration of the applied voltage.

In a nine-facet system 40 degrees is scanned each 1/24th second period. This corresponds to a pulse width of 83 microseconds. Hence, a cell pulse duty cycle is 83 microseconds of 48 Kilovolts repeated each 1/24th second.
 $E = 387 \times 10^{-12} \times (48 \times 10^3)^2 = 0.477 \text{ watt-seconds}$

$$\frac{0.477}{83 \times 10^{-6}} = 5.4 \text{ KW}$$

Since there are 12 cells stacked vertically to make up one slit, the total power required to charge the entire slit capacity = $12 \times 5.4 \text{ KW} = 65 \text{ KW}$.

RESISTIVE POWER DISSIPATION

Since cell resistance is 1 meg-ohm, 12 cells driven in parallel for the equivalent of one slit would make a parallel load resistance of

$$10^6/12 = 83 \text{ K ohms/slit} = R'$$

The DC power dissipation in the slit is then;

$$P = VV^2/R' = (48 \times 10^3)^2 / 82 \text{ K} = 28.2 \text{ KW}$$

TOTAL GENERATOR POWER REQUIRED FOR ENTIRE SYSTEM

The total generator power required to charge the slit capacitance and provide for slit resistive dissipation is $65 \text{ KW} + 28.2 \text{ KW} = 93.2 \text{ KW}$. For a 48 KV generator, the pulse current equals

$$I = \frac{93.2}{48} = 1.94 \text{ Amps.}$$

Since 3 slits across the screen (separated by 40°) will always be "on" at any one time, a total generator capacity of 280 KW is required. NOTE: Hipotronics, Inc., carries a complete line of unregulated high voltage power supplies. Among their line is a 50 KV - 2 Amp. supply. Three of these would provide the required power to drive the entire system.

If the cells were ultra-sonically cleaned and the nitrobenzene distilled into them, the resistivity of 10^{10} ohm-cm could theoretically be achieved and the resultant cell resistance would then make the resistive power dissipation negligible. In this case, the total system power would be 195 KW or 3 units of 50 KV each with a 1.35 Ampere capacity would be used.

FINAL STEREOSCOPIC ILLUMINATION AVAILABLE TO AUDIENCE

There is no doubt that this system tends to be inefficient from the standpoint of illumination to the observer. The $f/45$ projection system is inherently glossy with some improvement possible by the efficient utilization of the spherical lenticule and associate extended point source illuminators (as discussed in "Projector Concept to Improve Light Output"). The Kerr Cell only provides about 30% efficiency in the transmission of light. The percentage of the "on to off" time (duty cycle) of the slits in a 9-facet system (40 degree projector separation is $3/1500 = 1/500$).

The percentage to which the screen illumination (given in foot Lamberts) is reduced in passing through the Kerr cells and undergoing the slit duty cycle is $\frac{30\%}{500} = 0.06\%$.

Since the low end of the "standard" acceptable tolerance for indoor theatre screen illumination is 10 ft. Lamberts, the effective screen brightness would have to be 16,600 ft. Lamberts. It is obvious then, that a semi-specular type of screen is required.

From Figure 19 it was noted that any arbitrary screen element (x) must radiate over a 36 degree horizontal angle. However, it need not continuously radiate over this angle. In fact, it need only direct a fraction of one degree of incident illumination to the slit. As the slit moves from A to K, this narrow horizontally sweeping beam would have to be controlled to keep the screen illumination directed to the slit position.

This fan shaped beam would have a horizontal angle, determined by a 0.83 inch slit width at a distance of 50 feet, and approximately a 30 degree vertical angle which would cover the audience. The means for controlling such a beam at each of the screen's vertical elements has not been discussed within this paper, but the theoretical light gains as a result of employing this concept will be mentioned.

Figure 41 shows a theoretical "Lambert surface" (13) which has all of its radiation directed into the solid angle determined by the fan shaped beam. Since luminance = flux/unit solid angle, if the flux is maintained constant and the solid angle is decreased, the luminance increases.

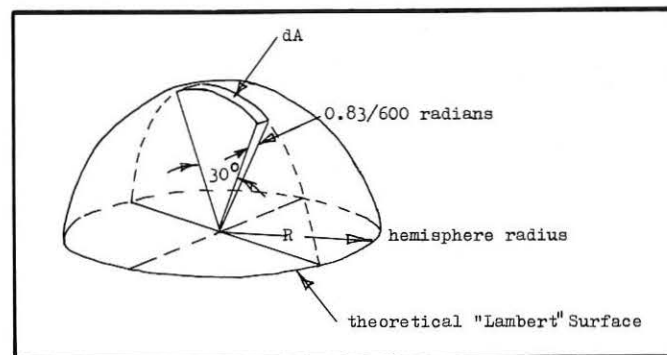

FIGURE 41: Increased luminance due to compression of solid angle from ideal Lambert surface with hemisphere coverage to fan-shaped beam

There are 2π steradians in a hemisphere. Assuming that the available light flux radiated from the ideal "Lambert surface" (which has an equal illumination as viewed from any angle) is packed into the fan-shaped beam in Figure 41, then the ratio $^A H/dA$ = the theoretical screen gain available; where $^A H$ is the surface area of the hemisphere and dA is the surface area on the hemisphere intercepted by the solid angle of the fan shaped beam.

$$\frac{^A H}{dA} = \frac{2\pi R^2}{\frac{\pi R}{6} \times \frac{0.83}{600} \times R} = 8700$$

Since the solid angle = surface area/(radius)², when the ratio of two areas of the same surface radius is taken, the R² term drops out.

Therefore, the theoretical screen gain (assuming a semi-specular operation) is 8700.

The screen illumination from the projected light is:

$$E = \frac{\pi B}{4 (MN)^2} \text{ where } E \text{ is the screen}$$

illumination in ft.-candles, "B" is the projector source brightness viewed through the exit-pupil of the projection lens (in Candles/ft²), "M" is the magnification which is unitless and equals the average projection throw distance divided by the projection lens focal length and "N" is the f-number of the projection lens.

The brightness of the source (assuming a Xenon short arc 5 KW source) is 3.72×10^8 candles/ft² approximately.

The magnification for a 133 foot throw and a 4.35 inch focal length is 367. "N" was previously calculated at 45.

From these figures, the screen illumination due to projection is 1.1 ft candles. With a theoretical screen gain limit of 8700 and an 0.06% output due to shutter-losses, the final available illumination to the audience = (1.1) (8700) (0.06%) = 5.8 ft. Lamberts.

Although this is below the recommended indoor theatre illumination, drive-in theatres operate with about 3 foot Lamberts of screen illumination. This is possible as the eye has a logarithmic response to a vast range of illumination. Also since the flicker rate is only 24 cycles per second, the "lower" illumination rate tends to provide a flicker-free presentation.

CONCLUSION (14)

Aside from the fact that our prosperous nation is lagging the rest of the world in stereo-projection systems, it is not progressive to assume that the silver-screen will remain flat forever. Pioneering initiative, both financial and experimental, is required to make life inside the theatre as realistic as it appears outside.

BIBLIOGRAPHY

1. F. Savoye patent No. 2,421,393—June, 1947.
2. H. E. Ives "Optical Properties of a Lippman Lenticulated Sheet" Bell Telephone System—Monograph B-558.
3. H. E. Ives "The Problem of Projecting Motion Pictures in Relief" —Bell Telephone System—Monograph B-672.
4. R. B. Collender—"The Stereoptilexer—Competition for the Hologram"—Journal Society for Information Display—Nov/Dec 1967—Vol 4 No 6, Pg. 27.
5. R. B. Collender "The Stereoptilexer"—Journal—Society of Photo-Optical Instrumentation Engineers—Oct/Nov—1967 Vol 6—No 1—Pg 14.
6. R. B. Collender "Recent Developments in Stereo Without Glasses" —American Cinematographer—Oct 1965—Pg 650.
7. J. S. Courtney—Pratt—"Image Dissection in High Speed Photography"—Photographische Korrespondenz, Darmstadt—1958.
8. N. A. Valyus—"Stereoscopy"—Focal Press, New York, printed 1966, Pg 195.
9. H. C. Schepler "Photo-optics Notebook (Pinhole Camera)"—Journal—Society of Photo-Optical Instrumentation Engineers—Feb/Mar 1967—Vol 5—No 3—Pg 133.
10. Kazuo Sayanagi "Pinhole Imagery"—Journal of the Optical Society of America—Sept 1967—Vol 57—No 9—Pg 1091.
11. A. M. Zarem "An Electro Optical Shutter for Photographic Purposes"—AIEE—1949—Paper 49-24.
12. "Spark Gap Breakdown Voltages"—Reference Data for Radio Engineers—4th Edition—IT & T—1959—Pg 921.
13. H. R. Luxenberg & R. L. Kuehn—"Display Systems Engineering"—McGraw-Hill Book Co., New York, copyright—1968—Pg 75.
14. R. B. Collender "Adapt Holograms to 3-D Projection?" Society of Photo-optical Instrumentation Engineers—Glass—Feb 1967—Vol 2—No 8 Pg 7.



ROBERT B. COLLENDER received his B.S. degree in Electronic Engineering from the University of California (Los Angeles). For the past 15 years, he has actively pursued the difficult problems of true stereoscopic photographic imaging without the use of optical aids at the observer's eyes.

In addition to this, his work in the aerospace industry involves satellite ground support equipment design in the field of electronics applied to optical and infrared systems.

Mr. Collender is presently with Lockheed Aircraft Corporation's Advanced Development Group in the capacity of Systems Application Engineer related to reconnaissance sensing equipment and ASW display devices.

Experimental evaluation of the resolution capabilities of image-transmission systems

by

D. R. KNUDSON, S. N. TEICHER,
J. F. REINTJES, AND U. F. GRONEMANN

ABSTRACT

The resolution capabilities of an experimental image-transmission system intended for microfilm library application have been investigated. The modulation-transfer-function concept is used as a quantitative measure of component and overall-system performance. The theory of MTF is discussed with emphasis on the analogy between the spatial- and temporal-frequency domains. Practical techniques for measuring the MTF's of electro-optical components are developed and results obtained from measurements made on specific components are presented. Also included in the paper are the conclusions which have been reached on line-scan requirements for a high-resolution microfilm facsimile system.

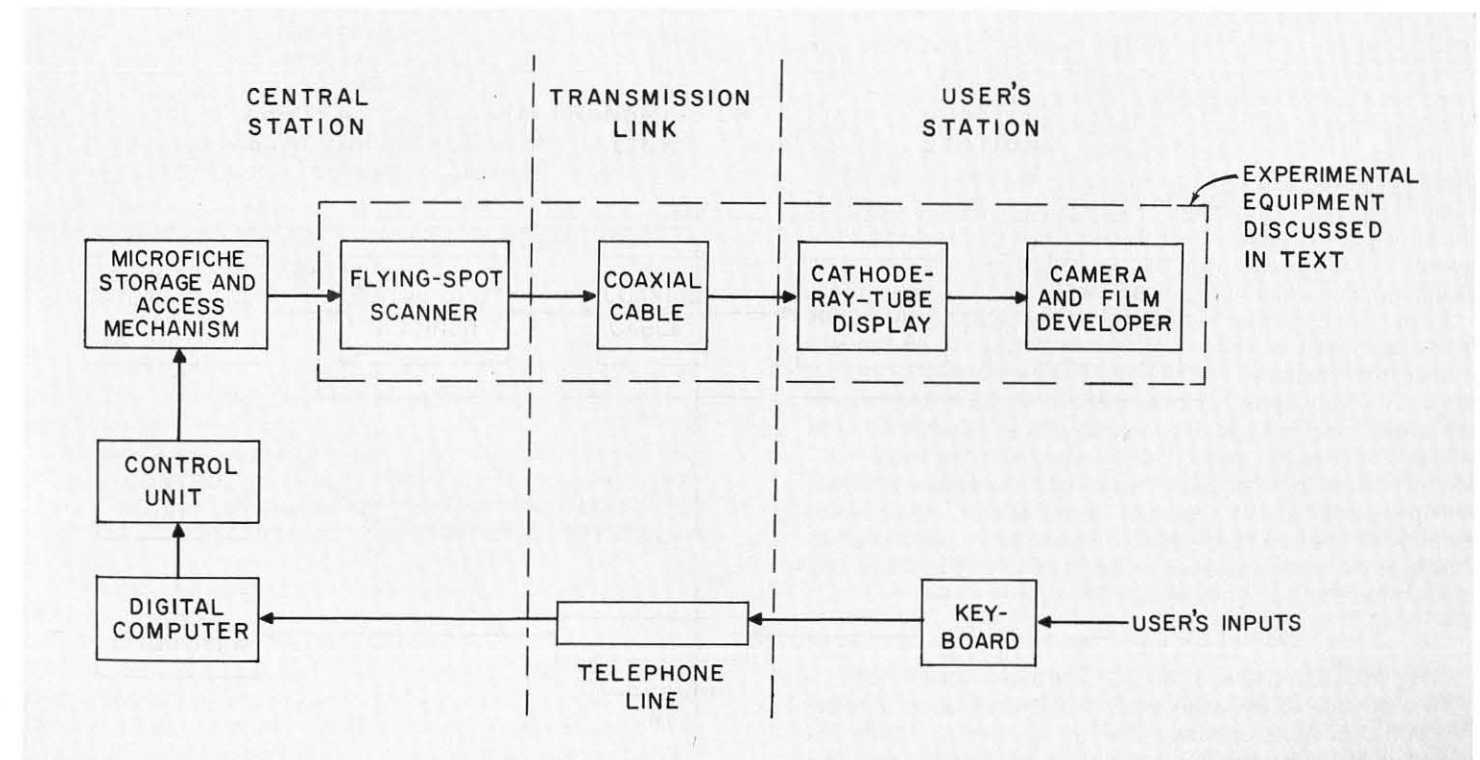

FIGURE 1: Block Diagram of a Remote Text-Access System

INTRODUCTION

During the course of investigations of techniques for providing rapid access to library information, a need has occurred to make experimental evaluations of the resolution capabilities of electro-optical systems which transfer microfilm images from one location to another. The results of these evaluations are reported here.

It is well known that photographic film provides a highly satisfactory medium for storing the alphanumeric and pictorial information contained in libraries. Film is compact, durable, and has a high resolution capability. Since it can accommodate information in analog (image) form, there is no need to digitize the information before storage. It can, of course, accept digital information, should there be a reason for digital encoding.

As libraries become hard-pressed for storage space, there is a growing trend toward use of microfilm as a means for conserving space. Extensive use of microfilm in a library, however, poses serious problems of information handling and retrieval. Retrieving a specific item quickly from a huge file, preserving film quality in the face of repeated handling, and maintaining accurate files, represent some of the difficulties which one encounters in the practical operation of a microfilm library. Moreover, a microfilm library does not, inherently, meet a highly desirable requirement of a modern library, namely that of providing guaranteed, rapid access to the full text of documents at stations which are remote from the store. As a means for providing this kind of service, the microfilm image-transmission system illustrated in Figure 1 has been investigated.

In Figure 1 textual information is stored on microfilm and held in an automatic fiche-and-frame selector, which is under computer control. A document is ordered by entering its numerical address into a computer. The desired frame of the microfilm image is then positioned automatically in front of a flying-spot scanner which serves to convert the photographic image into electrical signals. After appropriate synchronizing signals are added, the composite video signal is transmitted over a radio or wire transmission link to a receiver cathode-ray tube. The received image is captured on film and made available, after development, to the user. A feature of the microfilm system illustrated is that each microfiche frame needs to be scanned only once; the film at the receiver serves as the local storage medium. Elimination of a refreshed display conserves bandwidth and allows the scanner to be time-shared among several user stations.

A key issue in the design of the microfilm facsimile system is the number of scanning lines required in order to reproduce images with acceptable quality at the remote receiving station. Related to this issue, in turn, are the design specifications for each component of the system in order that the required overall quality can be realized. These matters were examined as part of our investigations.

In our experimental evaluation of the resolvability of the image-transmission system shown in Figure 1, we sought quantitative measurement techniques which could be related to the resolvability of each component of the system and to the overall system itself. Techniques such as slit methods and the shrinking-raster method of measuring cathode-ray tube spot size, and knife-edge and square-wave-response methods for measuring spatial-frequency responses of lenses were employed. The results of these measurements were used to derive resolution capabilities in terms of spread function and modulation transfer function.

THE MODULATION-TRANSFER-FUNCTION CONCEPT

As a prelude to the application of the modulation-transfer-function concept to an image-transmission system, a brief discussion of optical transfer function is presented here. The optical-transfer-function concept is an application of linear-

system theory to optical images. For a given magnification ratio, this function is uniquely determined by the relationship between the intensity distributions of the image and object of an optical device. If an analogy is made between spatial frequency, measured in cycles per millimeter, for optics, and temporal frequency, measured in cycles per second (Hertz), for networks, we can then adapt the rich body of techniques developed for analysis of linear networks to optical systems. The object-image relationship in the optical case corresponds to the input-output relationship in the linear-network case.

The Spread Function

The physical significance of the optical transfer function can be explained, using a lens as an example. Consider the image formed by a lens placed before a point light source, as in Figure 2. Because of diffraction and lens aberrations, the

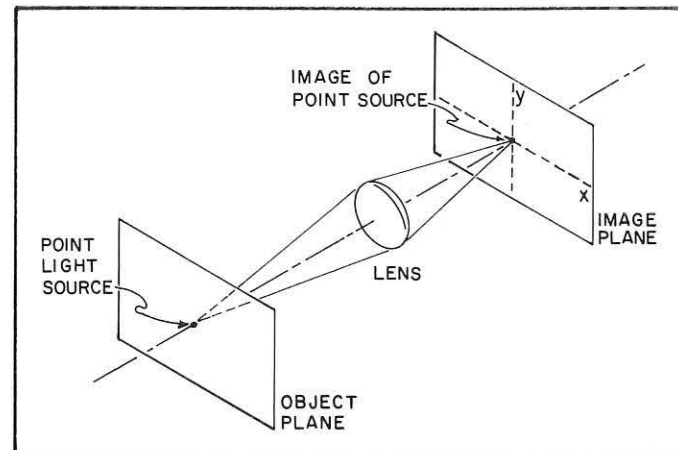

FIGURE 2: A Lens Used to Image a Point Light Source

image will not be a point, but will be spread over a finite area in the image plane. The intensity distribution $p(x,y)$ of the image of a point source is called the spread function of the lens and looks typically like the contour drawn in Figure 3. The spread function may be regarded as a two-dimensional response of a lens to a spatial impulse, defined as a point light source with zero area and finite flux. Although spatial impulses can only be approximated in practice, the concept is useful for analysis of optical devices, in the same way that the time-impulse concept is a valuable analytical tool in networks. If the object in Figure 2 were a line source of in-

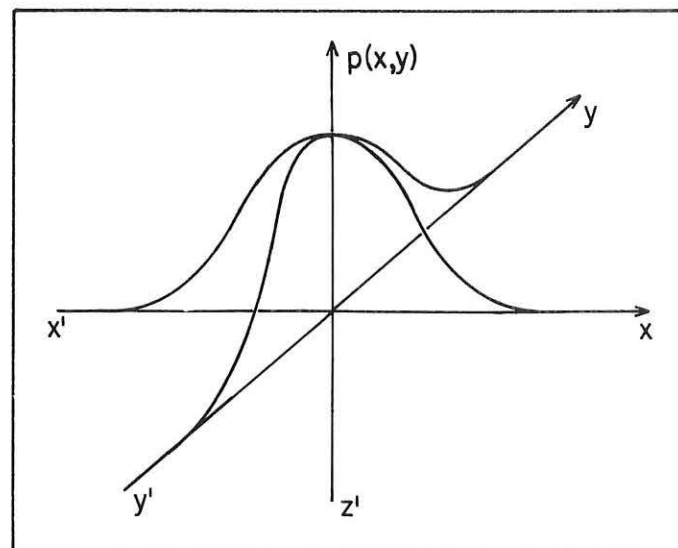

FIGURE 3: Two-Dimensional Spread Function of a Lens

finite length and zero width instead of a point source, the intensity distribution $l(x,y)$ of the image would have the form illustrated in Figure 4.

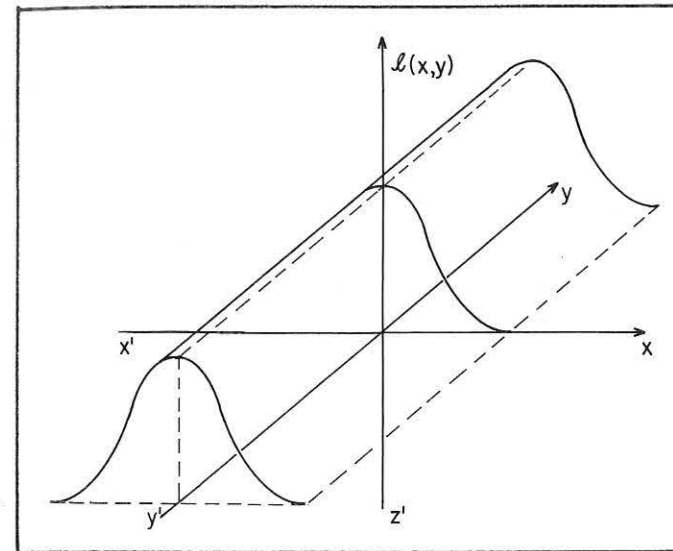

FIGURE 4: Line Spread Function of a Lens

This response is called the line spread function $l(x)$ and can be obtained by integrating the point spread function in one dimension:

$$l(x) = \int_{-\infty}^{\infty} p(x, y) dy \quad (1)$$

Thus $l(x,y)$ is reduced to a function of x only. The line spread function can be used for the evaluation of images in the x dimension whenever the intensity variation in the y direction is essentially constant; for example, lineal light sources parallel to the y axis.

In cases where the spread function remains essentially constant over the image areas, the lens can be considered as a linear spatial-invariant device, and the analysis is directly analogous to that for linear time-invariant systems; that is, the image intensity at any set of coordinates can be determined by taking a weighted sum of the impulse responses from each point in the object. Consider a small object on-axis whose intensity distribution varies only in the x direction; and assume the intensity distribution, referred to the image plane, is $f(x)$. The image intensity $g(x)$ is the weighted sum of the impulse responses from each point in the object and is expressed mathematically as a convolution integral. Thus,

$$g(x) = \int_{-\infty}^{\infty} f(x - \sigma) l(\sigma) d\sigma \quad (2)$$

where σ is a substitute variable of integration.

Spatial-Frequency Domain

In general, the evaluation of the convolution integral may be a difficult task. However, it is known from linear-system theory that transforming the problem into the frequency domain by means of Fourier transforms offers mathematical simplification as well as additional insight.

Consider an object with an intensity distribution which is a spatial sinusoid of unity amplitude in one dimension and which is constant in the other dimension. The image formed by the lens of this spatial sinusoid can be determined from the convolution integral and is derived as follows. Let $f(x)$ be the object intensity referred to the image plane. Then $f(x) = \text{Im} [e^{j\omega x}]$, where Im signifies the imaginary part of the operator. The image intensity distribution $g(x)$ is determined

by the convolution integral, as in Equation 2. Substituting for $f(x-\sigma)$ gives

$$g(x) = \int_{-\infty}^{\infty} l(\sigma) \text{Im} [e^{j\omega(x-\sigma)}] d\sigma \quad (3)$$

Since the line spread function $l(\sigma)$ is a real function, this equation can be rewritten as

$$g(x) = \text{Im} [e^{j\omega x} \int_{-\infty}^{\infty} l(\sigma) e^{-j\omega\sigma} d\sigma] \quad (4)$$

The Fourier transform $L(\omega)$ of the line spread function is defined as

$$L(\omega) = \int_{-\infty}^{\infty} l(\sigma) e^{-j\omega\sigma} d\sigma \quad (5)$$

Therefore, the intensity distribution of the image is

$$g(x) = \text{Im} [e^{j\omega x} L(\omega)] \quad (6)$$

If the spread function is an even function of x , its Fourier transform is a real function, and Equation 6 reduces to:

$$g(x) = \text{Im} [e^{j\omega x} L(\omega)] = L(\omega) \text{Im} [e^{j\omega x}] = L(\omega) f(x) \quad (7)$$

If the spread function is not an even function of x , $L(\omega)$ is a complex variable which can be expressed as a magnitude and phase angle. In either case, the image intensity varies sinusoidally in the x direction with the same spatial frequency as the object, but with an amplitude determined by the magnitude of $L(\omega)$. Thus, the Fourier transform of the spread function represents the spatial-frequency response of the lens and is analogous to the frequency response used in the analysis of dynamic systems.

The complex-frequency response $L(\omega)$ is known as the *optical transfer function*. Although the spatial phase angle is necessary for a complete evaluation of the image, the magnitude is the important part of the function when considering resolution limits and it will be the primary interest in the remainder of this paper. The *modulation transfer function* (MTF) is a normalized version of the magnitude and is defined as the ratio of the magnitude of the response at each frequency to the magnitude of the response at zero frequency:

$$\text{MTF} = \left| \frac{L(\omega)}{L(\omega)_{\omega=0}} \right| \quad (8)$$

The primary simplification that results from substitution of the frequency domain for the spatial domain is that the convolution integral transforms into a simple multiplication. (See, for example, Y. W. Lee, *Statistical Theory of Communications*, Chapter 13, John Wiley and Sons.) Thus, the amplitude of the image-intensity variation for an object which is a spatial sinusoid is simply determined by the magnitude of the MTF at that spatial frequency. Since any finite object can be represented as a sum of sinusoids by means of a Fourier series, the amplitudes of the frequency components in the image of any object can be determined.

The frequency-domain approach is partially useful when applied to systems employing combinations of optical components. For example, cascaded lenses, where the image of one becomes the object of the other, have an overall spread function which is the convolution of the individual spread

functions. In the frequency domain, the magnitude of the overall MTF is simply the product of the individual MTF's. For such systems, the effect of each lens on the overall image quality is much more easily understood from its MTF than from its spread function. The concept of an optical device as an image-transfer mechanism with limited spatial bandwidth can be quite useful in the design and analysis of complicated optical systems.

When MTF's of cascaded components are combined, the scaling changes of spatial frequencies caused by the magnification ratios of lenses must be considered. The magnification ratio determines the relationship between the spatial frequencies in image and object planes of the lens. For example, 10 cycles/mm in the object plane of a lens used at a 2 to 1 reduction ratio corresponds to a spatial frequency of 20 cycles/mm in the image plane. *Before the MTF's of cascaded components can be multiplied, all components must be referenced to a common plane by means of a suitable magnification ratio.*

Nonlinear components (for example, photographic film) must be treated carefully when using MTF techniques to analyze a system. Nonlinear analysis can become quite cumbersome and a discussion of it is not included here. Nonlinear behavior in the optical domain, as in the electrical and electromechanical domains, can be handled by small-signal linear approximation techniques when small-signal conditions prevail.

ELECTRO-OPTICAL MEASUREMENTS OF CATHODE-RAY-TUBE SPOTS

A cathode-ray tube (CRT) is commonly used in image-transmission systems in two different ways—as part of a flying-spot scanner at the transmitter and as an image-forming device at the receiver. The function of the flying-spot scanner is to convert the input image into an electrical signal. In the experimental system of Figure 1, the input is a microfilm image of a page of text and the flying-spot scanner is used to convert the text to a video signal. A CRT provides a spot of light which approximates a point source of constant intensity. The spot is scanned in a predetermined pattern through deflection of the CRT electron beam. An objective lens located between the CRT and microfilm projects the scanning light source onto the film and the light transmitted through the film is detected by means of a photomultiplier tube (PMT). Time variations in the amplitude of the electrical signal from the PMT corresponds to the spatial variations in the density of the microfilm image along with the scanning path. In Figure 1 the scanning pattern is a noninterlaced raster consisting of a series of uniformly spaced scan lines of equal length. The raster is generated by deflecting the CRT beam at a constant rate in the horizontal direction and at a much slower constant rate in the vertical direction.

The receiver CRT serves to reconstruct the input microfilm image. The receiver CRT spot is raster-scanned in synchronism with the transmitter CRT spot and the receiver intensity is modulated in accordance with the video signal. In the system of Figure 1 a single frame on the microfilm is scanned only once; a camera is used to project and store the reconstructed image on 35-mm film as the image is regenerated.

CRT Requirements in Image-Transmission Systems

The resolution of both transmitter and receiver CRT's is limited by the size of the CRT light spot. The intensity distribution of the spot along any linear dimension represents the spot spread function of the CRT along that dimension. The narrower the spread function, the closer together are the individual image elements that the CRT can resolve. Hence a narrow CRT-spot spread function is a prime requirement in high-resolution image-transmission systems.

Another common requirement for the scanner and receiver

CRT's is high light output. In the flying-spot scanner, the signal level at the input to the photomultiplier tube is proportional to the CRT light intensity. At the receiver, high light intensity is required, particularly at high scan rates, to ensure sufficient exposure of the film.

A fundamental difference in the requirements for the two CRT's is their phosphor response times. The decay characteristics of the CRT phosphor can have a significant effect on the spot intensity distribution at high scan rates. A slow decay in light output of the phosphor after removal of its excitation causes a tail on the trailing edge of the CRT spot. In the transmitter CRT this tail has the effect of widening the spread function of the spot in the direction of scan and thus the effect of degrading the horizontal resolution of the video signal. To minimize this effect, the CRT in the scanner in Figure 1 uses a P-16 phosphor, which has the fastest response of currently available standard phosphors; it decays to 10 percent of its original intensity within 0.12 μ sec after its excitation is removed.

For an image-forming CRT as in the receiver of Figure 1, phosphor decay rate has essentially no effect on the CRT resolution. It is the spatial distribution of the total light energy from the phosphor that determines the receiver image resolution rather than the instantaneous distribution, as in the scanner. Hence, the slower, but more efficient, P-11 phosphor is used in the receiver CRT.

The electron beam of a flat-face CRT tends to become defocused as it is deflected from the principal axis of the tube. Dynamic-focus circuitry should therefore be used to compensate for off-axis defocusing in high-resolution systems. These circuits sense the horizontal and vertical-deflection signals and provide an appropriate variable component to the focus voltage or current.

The CRT spot size also tends to increase with beam current. Furthermore, the saturation effects of the phosphor can change the shape of the intensity distribution of the spot as the beam current is increased, thus causing a flattening of the peak of the intensity-distribution curve. In the flying-spot scanner, the CRT spot in each area of uniform focus can be represented by a constant spread function since the beam current is constant. In the receiver, however, the beam current is modulated by the video signal. The spread function of the receiver CRT spot is therefore dependent on the signal level.

Shrinking-Raster Measurements

One method commonly used to measure CRT spot size is the shrinking-raster method. A raster scanning pattern consisting of equally spaced scan lines is generated by scanning the CRT beam repetitively in the horizontal and vertical directions with the scan rate in one direction two or three orders of magnitude faster than the rate in the other direction. The scan lines are viewed through a microscope and the length of the raster in the slow-scan direction is reduced until the scan lines are no longer visible as individual lines. The spot diameter is considered to be the length of the raster under this condition divided by the number of scan lines comprising the raster. The time interval between adjacent scan lines should be long compared with the phosphor decay time so that the light distribution for each scan line is not affected by the preceding scan line. Also, the beam-deflection signal in the slow scan direction must be free from any ripple.

For the experimental system of Figure 1, Litton Industries Type 4123, five-inch diameter CRT's are used with magnetic deflection and focusing. The P-16 phosphor is used in the transmitter tube and P-11 is employed in the receiver tube. Shrinking-raster measurements on these tubes at beam currents in the 1- to 3-microamp range showed spot sizes ranging from 0.8 mil to 1.4 mils. At least part of this variation is attributable to uncertainties in the measurement technique.

The shrinking-raster method of spot-size measurement is commonly used because it is easy to implement and because the only equipment required is the deflection electronics of the CRT and a microscope for viewing the raster lines. A disadvantage of the method is that it does not yield accurate, repeatable results because of its dependence on the judgment and visual acuity of the person viewing the raster lines. The intensity of ambient light during the tests can also influence results.

The most serious disadvantage of the shrinking-raster method, however, is that it provides only a measure of the limiting resolution of the CRT rather than a measure of its response over a range of spatial frequencies. The human eye is generally considered capable of detecting a minimum of 2- to 5-percent modulation of intensity. Hence, the spacing of the raster lines where the individual scan lines become indistinguishable represents a point on the modulation transfer function of the CRT where the high-spatial-frequency response is reduced to a few percent. Because only one point of the MTF curve is measured, no direct information is obtained about the rest of the curve.

If the intensity distribution of the CRT spot is assumed to be some analytic function (such as a Gaussian distribution), the shape of the MTF curve is implied by the function, and in theory, the MTF can be derived by passing an appropriate curve through the point determined from the shrinking-raster measurement. In practice, however, the deficiencies of the shrinking-raster method prevent an accurate determination of the MTF even if the assumed intensity distribution is correct. When the CRT is part of an image system, knowledge of the response over a range of spatial frequencies is important because of the high spatial-frequency roll-offs of all the components and their contributory effects on the limiting resolution of the overall system. Thus, a method is required for determining the modulation transfer-function of a CRT. In practice, a simple technique is to measure the spread function of the CRT spot and then to derive its MTF analytically.

Slit Measurements

Instruments are available commercially for measuring the spot spread function of a CRT in one dimension.³ In these instruments a microscope serves to image the scanned spot on two slits in an opaque sheet located in the image plane of the microscope. The instantaneous light transmitted through the slits is detected by a photomultiplier tube and the detected signal is displayed on an oscilloscope. The spot spread function is determined from knowledge of the distance between slits, the magnification of the microscope and the oscilloscope trace.

A single-slit version of this measurement technique which requires a minimum of instrumentation is presented here. The configuration is shown in Figure 5. The microscope images the CRT spot onto a narrow slit as the spot is scanned at constant rate in a direction perpendicular to the slit. A photomultiplier-tube (PMT) converts the light through the slit into an electrical signal which drives the vertical deflection channel of an oscilloscope. The effect of the microscope is to enlarge the CRT spot. Figure 6 illustrates the positions of the slit and the spot image in the plane of the slit at one instant. The output of the PMT at this instant is proportional to the light transmitted through the slit. The total transmitted light, in turn, is equal to the integral of the spot intensity in the shaded area of Figure 6.

If the width of the slit is small with respect to spot size, the PMT signal is proportional to the intensity distribution and the trace of this signal on the measurement oscilloscope is the spot spread function of the CRT in one dimension. Figure 7 illustrates the appearance of the trace. The distance between

³For example, the two-slit spot analyzer manufactured by the Constantine Engineering Laboratories Company.

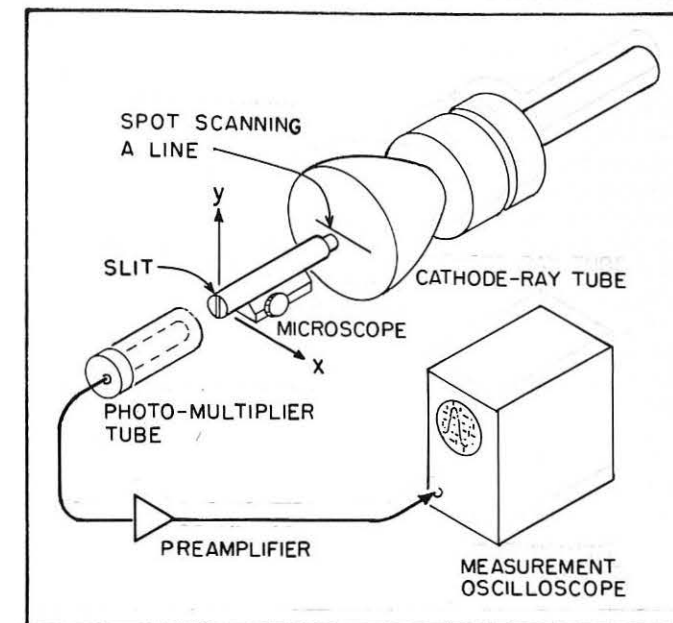

FIGURE 5: Test Setup for Measuring CRT-Spot Spread Function by Means of a Single Slit.

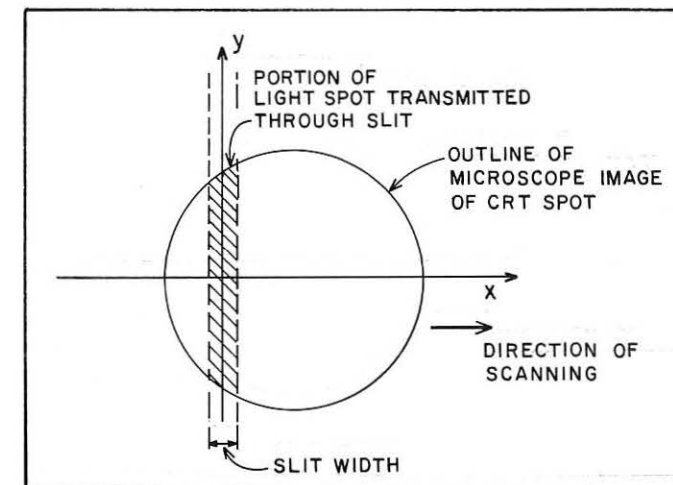

FIGURE 6: Position of Microscope Image of CRT Spot at One Instant During Slit Measurement

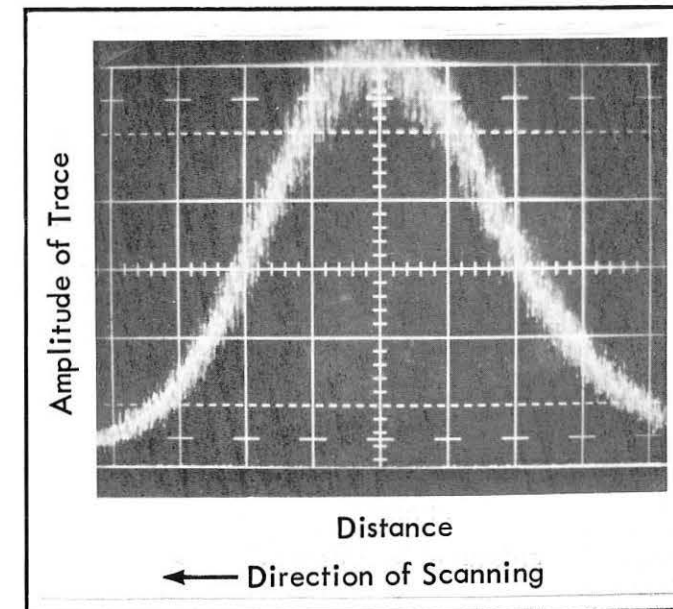

FIGURE 7: Spread Function of a Litton Type 4123 CRT as Determined by a Single-Slit Measurement

the points where the spread-function amplitude is one-half its maximum value is frequently used as a measure of spot width. The horizontal axis of the measurement-oscilloscope trace can be expressed in units of length along the x axis at the CRT by multiplying the length of the trace on the measurement oscilloscope by the ratio of the scan rates of the oscilloscope and CRT. The scan rate of the CRT can be determined by measuring the total length of the linear scan and the scanning time. Delayed and expanded sweep capabilities on the oscilloscope are important assets in implementing these measurements.

Experimental Results

Single-slit spread-function measurements were made on both the transmitter and receiver CRT's in the experimental portion of the system of Figure 1. The test conditions for the measurement of Figure 7, which is for the Litton Type 4123 tube, are:

CRT beam current = 0.1 μ amp

CRT scan rate = 4.2 in./sec

measurement-oscilloscope horizontal sweep rate = 50 μ sec/cm

The CRT-spot diameter at the half amplitude of its spread function is determined as follows:

half-amplitude width of trace = 4.1 cm

half-amplitude spot diameter = $d = 4.1 \text{ cm} \times 50$

$\times 10^{-6} \text{ sec/cm} \times 4.2 \text{ in./sec}$

$= 0.86 \times 10^{-3} \text{ in.}, \text{ or } 0.86 \text{ mil.}$

The noise on the trace of Figure 7 is caused by a combination of phosphor and PMT noise. The half-amplitude spot diameter was determined from an average curve drawn through the trace.

The half-amplitude diameter of the CRT spot was found to be sensitive to focusing current. At optimum focus, the half-amplitude diameters of the scanner and receiver CRT's at 1 μ amp beam current were 1.2 and 1.0 mils, respectively, at the center of the tube face. Through use of dynamic-focusing circuitry, it was possible to constrain the variations in spot diameter to ± 15 percent of its diameter at the center of the CRT at all points within a 2.5-inch by 3.5-inch raster.

The effect of beam current on spot size of a Litton Type 4123 tube is illustrated in Figure 8. Data for the curve were

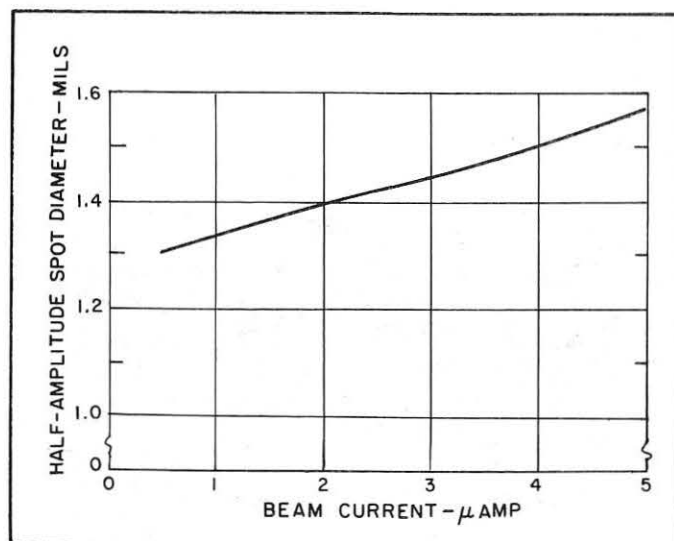

FIGURE 8: Effect of Beam Current on Scanner CRT Spot Size

taken for the spot located at the center of the tube and for a constant focus current.

Figure 9 shows the influence of slow decay in phosphor response on the shape of the spread function. The pronounced tail is on the trailing edge of the trace. The trace in Figure

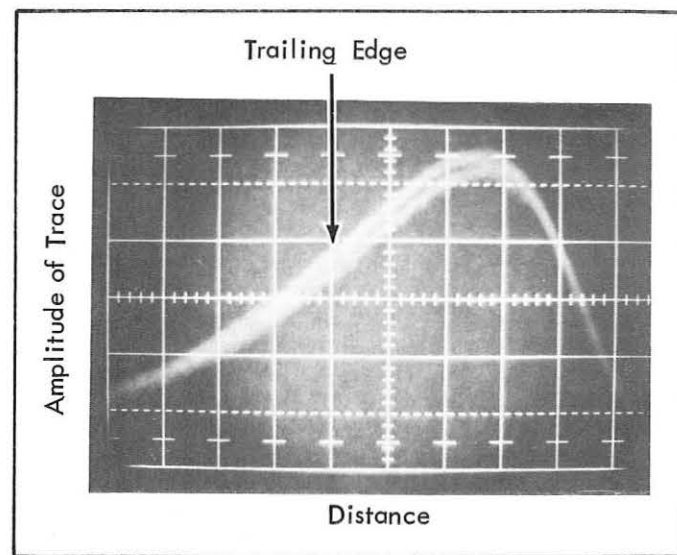

FIGURE 9: Effect of Phosphor Decay

9 was recorded for the transmitter CRT, which uses P-16 phosphor, at a scan rate of 10,000 in./sec and a beam current of 3 μ amp. For P-16 phosphor the tailing effect was observable at scan rates above 3,000 in./sec, whereas for P-11 phosphor it became apparent at scan rates above 6 in./sec.

MTF Calculation

The modulation transfer function of the CRT in the direction of scanning is the Fourier transform of its spread function. Determination of the Fourier transform of a spot with a generalized intensity distribution can be a lengthy computation which is best accomplished by quantizing the spread-function data and using a computer to calculate its transform.

The computation is greatly simplified, however, when the line spread function can be represented by a Gaussian function. The central-limit theorem of probability theory states that the probability distribution of a normalized sum of n independent random variables approaches a Gaussian distribution as n becomes large. Since the CRT spot is generated by bombardment of the phosphor by many electrons randomly distributed around a point, it is reasonable to expect that the CRT line spread function approximates a Gaussian function.

A comparison of the slit-measurement results obtained on the experimental system with a Gaussian curve revealed that the spread functions for these CRT's can be represented by a Gaussian function. For example, the spread function of the P-16 CRT measured at a beam current of 2- μ amp and at a scan rate of 550 in./sec differed from a true Gaussian curve by less than ± 2 percent of its peak value.

For a spot with Gaussian intensity distribution the slit measurements can be used to derive an analytic expression for the line spread $l_g(x)$:

$$l_g(x) = e^{-\frac{x^2}{2\sigma_x^2}} \quad (9)$$

The standard deviation σ_x of the Gaussian function can be related to the value x_1 at which the amplitude is one-half its peak value through use of Equation 9; the relationship is $\sigma_x = 0.85 x_1$.

$$\sigma_x = 0.425 d \quad (10)$$

Therefore, the analytic expression for the line spread function of the Gaussian spot can be determined directly from a lineal measurement on the trace of the slit measurement.

The Fourier transform of a Gaussian function is:

$$\int_{-\infty}^{\infty} e^{-\frac{x^2}{2\sigma_x^2}} e^{-j\omega x} dx = \sqrt{2\pi}\sigma_x e^{-\frac{\omega^2\sigma_x^2}{2}} \quad (11)$$

The MTF is the Fourier transform of the spread function normalized so that its magnitude at zero spatial frequency, $\omega = 0$, is equal to unity. Since the magnitude of the Fourier-transform expression at $\omega = 0$ is $\sqrt{2\pi}\sigma_x$, the MTF of the Gaussian spot (MTF_g) is:

$$MTF_g = e^{-\frac{\omega_x^2\sigma_x^2}{2}} \quad (12)$$

where ω_x represents the angular spatial frequency in radians/unit distance in the x direction.

Equations 10 and 12 permit the MTF to be plotted from the results of the slit measurement. Figure 10 illustrates the MTF of the receiver CRT where the spatial frequency is measured in the plane of the CRT screen.

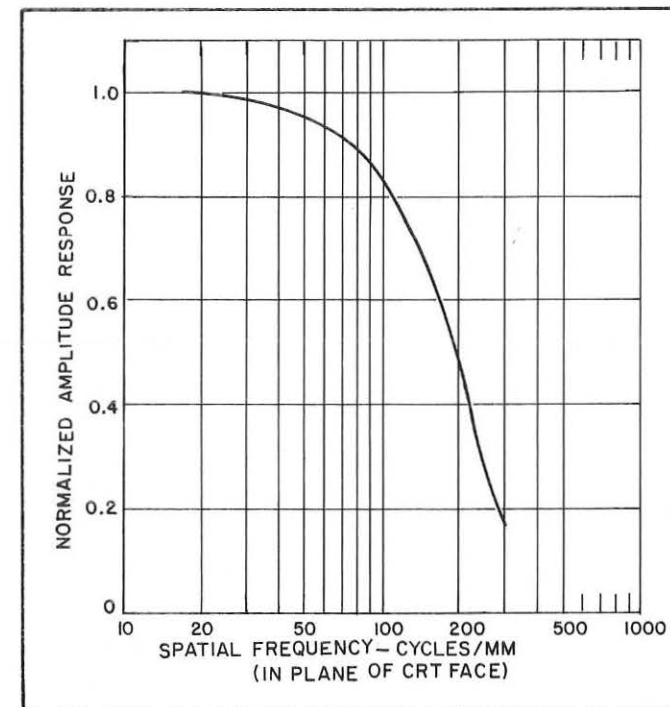

FIGURE 10: Modulation Transfer Function of Receiver CRT

The width of the slit used for these measurements theoretically should approach zero to provide an exact sampling of the intensity distribution. However, a narrow slit limits the light transmitted to the PMT and reduces the signal-to-noise ratio of the measurements. The light transmitted through the slit is equal to the integral of the intensity distribution in the shaded area of Figure 6. For a Gaussian intensity distribution, numerical tables of integrals can be used to show that less than five percent error in the half-amplitude diameter occurs with a slit width as large as the standard deviation σ_x multiplied by the magnification ratio on the spot. With a ten-power microscope, a three-mil slit can be used to measure a one-mil spot with a resulting error of a few percent. The relative insensitivity of the measurement to slit width is a favorable factor in the implementation of these measurements.

MEASUREMENT OF MODULATION TRANSFER FUNCTIONS OF LENSES

Two different types of lenses are commonly used in image-transmission systems; an objective lens, which is included in the transmitter scanner and in the receiver camera, and a condensing lens, which is employed in the scanner. The condensing lens directs the light transmitted through the microfilm image onto the photo-cathode of the PMT. The input to the PMT is the total light flux passing through the condensing lenses and is not a function of the spatial distribution of the transmitted light rays. By collecting more of the transmitted light, the condensing lenses can increase the signal level at the PMT, but their imaging qualities have no direct effect on system resolution. The objective lenses, on the other hand, provide a spatial transfer of the intensity distribution from one plane to another, and the spatial-frequency characteristics of these lenses directly influence system restoration. The scanner and receiver objective lenses represent cascaded elements of the image-transmission system and their modulation transfer functions are contributing factors of the overall system MTF.

Lens Requirements in Image-Transmission Systems

Because of diffraction, the image of a point light source which is formed by an ideal lens is a disk of finite area surrounded by concentric rings, or Airy disks, whose intensity decreases with their diameter. This ring pattern imposes an upper limit on lens resolution, and it can be shown that the limit is inversely proportional to the f -number of the lens. Since a low f -number lens corresponds to a large aperture, such a lens transmits a large fraction of the light available at the object. Hence, because a low f -number offers both high resolution and efficient transmission of light, it would appear that selection of the objective lenses for the scanner and receiver is reduced to the process of finding the lowest f -number lens. In practice, there are other important considerations, as discussed below.

In practice, it is difficult and expensive to achieve a diffraction-limited lens with a low f -number. Furthermore, the lens aberrations can reduce its resolution well below the diffraction limit. Lens resolution generally diminishes with increasing viewing angle with respect to its optical axis, and the required field of view to cover a given object size must be considered in selection of a lens. Also, constraints on the physical space available for the system may impose limitations on the lens focal length.

The custom design and manufacture of a lens for a specific application is a complicated, expensive task which can amount to several thousand dollars. On the other hand, a lens manufactured from an existing design or purchased as an over-the-counter item is likely to cost a few percent of that of a custom lens of comparable quality. Hence it is often worth the effort of trying to adapt the system design to accommodate an existing set of lenses. In summary, selecting the objective lenses for the scanner and receiver involves tradeoffs among resolution, light transmission, and cost.

In order to analyze and evaluate the resolution capabilities of an image-transmission system, the MTF's of the objective lenses in the system must be known. Unfortunately, adequate MTF data are normally not available from the lens manufacturer. We have therefore explored the following measurement techniques which may be utilized by individual groups as needed.

Edge-Response Measurements

The MTF of a lens can be determined directly by measuring the sinusoidal response of the lens over an appropriate range of spatial frequencies, or indirectly by measuring the response to non-sinusoidal objects (such as a knife edge) from which the sinusoidal response can be derived analytically. The direct method of measurement requires targets with densities that

vary sinusoidally in one direction over a range of spatial frequencies. These targets are difficult to produce accurately with high contrast at constant amplitude of modulation over a wide range of spatial frequencies. The indirect methods avoid the need for complicated targets, but require more computation for the derivation of the MTF.

Both types of measurements utilize a scanning or sampling of the image-object intensities in order to measure their spatial modulation. Since the CRT is a device generally available to the display designer, it is appropriate to exploit its ability to generate a scanning spot which approximates a point light source. As shown previously, the spatial-frequency response of a cascaded combination of elements is the product of the spatial-frequency responses of the individual elements. Since the MTF of a CRT spot can be determined by the method described in the preceding section, the MTF of a lens can be calculated from a measurement of the MTF of the cascaded combination of a CRT and lens by dividing the MTF of the CRT-and-lens combination by the MTF of the CRT.

A method which requires only very simple measurement equipment for determination of the MTF of a CRT-and-lens combination is illustrated in Figure 11. The measurement pro-

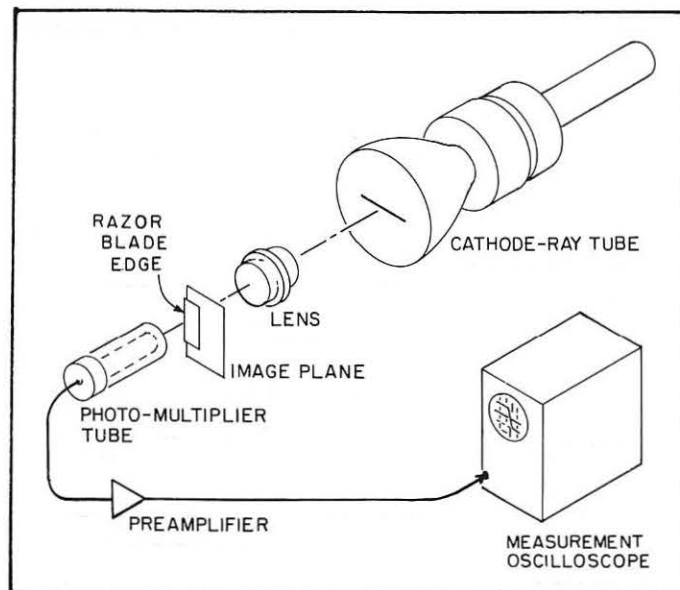

FIGURE 11: Test Setup for Making Edge-Response Measurements

cedure is as follows. The CRT spot is scanned repetitively along a line at a constant scan rate. An ordinary razor blade is used as a sharp edge in the image plane of the lens and is positioned so that its edge is perpendicular to the scanning direction of the CRT spot. The PMT detects the amount of light which is transmitted by the lens past the razor blade edge at each instant during the scanning of the CRT spot. The horizontal sweep of the measurement oscilloscope is synchronized with the sweep which produces the scanning of the CRT spot. The plane of focus for the lens is determined by moving the razor blade parallel to the optical axis until the slope of the oscilloscope trace is a maximum.

It will be recognized that the signal detected by the PMT passes from maximum to minimum value as the spot sweeps past the knife edge, and for constant scan rate the transition time is a function of the optical characteristics of the CRT-spot-and-lens combination. It should also be evident that the edge response of the optical system is analogous to the step response commonly used in linear network theory. Just as the impulse response of a network is the time derivative of its step response, the spread function of an optical device is the spatial derivative of its edge response. Thus, the spread function of the CRT-and-lens combination is the derivative of the measurement-oscilloscope trace obtained from the

edge-response tests, and the MTF of the combination is the normalized amplitude of the Fourier transform of the spread function. Measurements indicate that it is usually not possible to represent the spread function of the CRT-and-lens combination by a simple, analytic function. As a result, the calculations required for the derivation of the MTF from the edge response are quite lengthy but are easily carried out with the aid of a computer.

The flying-spot scanner and the receiver camera both use, as their objective lens, a Nikkor CRT recording lens with a 55-mm focal length. A series of edge-response tests were made on each of these lenses. The lenses have a variable aperture from f -1.2 to f -11; the tests were made over the range of f -2 to f -5.6. Figure 12 is an example of the oscilloscope trace ob-

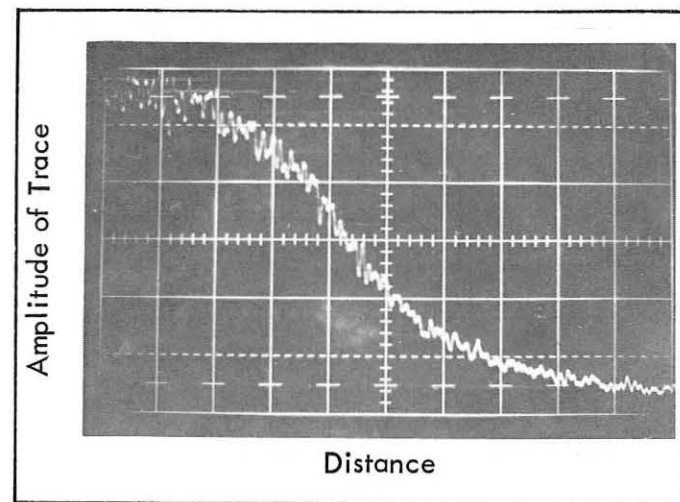

FIGURE 12: Edge-Response Measurement of Scanner CRT-Lens

tained from these measurements. The trace was taken with the scanner CRT and lens at f -2.8, a reduction ratio of 6.5 to 1, and a CRT scan rate of 550 in./sec. These parameters were chosen so as to be representative of conditions that prevail in the system of Figure 1.

As a first step in the calculation of the MTF of the CRT-lens combination, the measurement oscilloscope trace must be calibrated in terms of distance units in the image plane of the lens. If D represents distance on the screen of the measurement oscilloscope referred to the image plane of the lens under measurement,

$$D = \frac{(\text{sweep rate})_{\text{CRT}}}{(\text{sweep rate})_{\text{OSC}}} \times (\text{lens reduction ratio}) \quad (13)$$

The calculation then proceeds as follows. The calibrated edge response, such as that shown in Figure 12, is quantized by dividing the horizontal scale into an appropriate number of small equal increments, and the amplitude of the response is evaluated for each increment. We chose eighty increments for our evaluations and in order to eliminate the noise effects observable in the trace, we took amplitude measurements from a smooth curve drawn through the trace. Amplitude data were supplied to a digital computer which was programmed to calculate the derivative of the curve at each increment and to compute the Fourier transform of the derivative function. The MTF of the CRT-lens combination was calculated by normalizing the amplitude of the transform as determined by the computer with respect to its value at zero spatial frequency. The MTF of the CRT was obtained from a slit measurement, described previously, and converted to the image plane of the lens by multiplying the spatial-frequency scale by the reduction ratio between the CRT face and the image plane of the lens. For a reduction ratio of x to 1, a spatial frequency of 1 cycle/in. in the plane of the CRT face corresponds to x cycles/in. in the image plane. Finally, the lens MTF was de-

rived by dividing the MTF of the CRT-lens combination by the MTF of the CRT. The result of these calculations for the scanner lens at f -4 and a reduction ratio of 5.4 to 1 is illustrated by curve A of Figure 13.

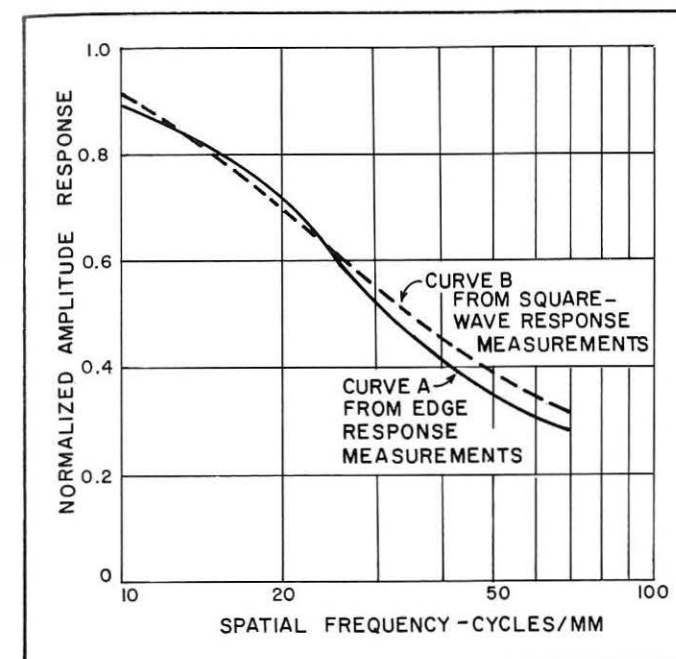

FIGURE 13: Modulation Transfer Function of Scanner Lens

Square-Wave Response Measurements

It is apparent that the relative simplicity of MTF measurements by means of the edge-response method is obtained at the expense of considerable computational complexity. It may occur to the reader that a single-slit measurement, similar to that described previously for the CRT, might be employed for the CRT-and-lens combination. In theory, the aerial image of the lens can be projected by a microscope onto a slit to measure the spread function of the CRT-and-lens combination, but the width of this slit compared to that used in the CRT measurements must be reduced by a factor equal to the lens reduction ratio. Because the smaller slit and the limited aperture of the lens reduce the light transmitted through the slit, it is difficult to achieve sufficient signal level at the PMT. In the edge-response tests, all the light transmitted by the lens is available to the PMT for detection of the knife edge and an adequate signal level is obtained.

An alternative approach for measuring the MTF of the CRT-lens combination can be used in order to reduce computation requirements with only a slight increase in the complexity of the targets. The test setup for this method is the same as that of the edge response shown in Figure 11 except that a target consisting of parallel, equally spaced clear and opaque strips replaces the razor blade. The target provides square-wave modulation of transmission with a spatial frequency equal to the reciprocal of the spacing between the opaque strips. A set of these targets covering the frequency range of interest can be used to measure the square-wave response of the CRT-lens combination as a function of frequency from which the MTF of the lens can be derived.

It was found that so-called "Ronchi rulings" provide excellent square-wave targets. These rulings are manufactured by applying an opaque layer to a glass base and removing equally spaced strips of this layer by machine so that the

widths of the transparent and opaque strips are equal.

These rulings are readily available in a one-inch square size over a wide range of spatial frequencies. The one-inch square size eliminates the edge effects that occur

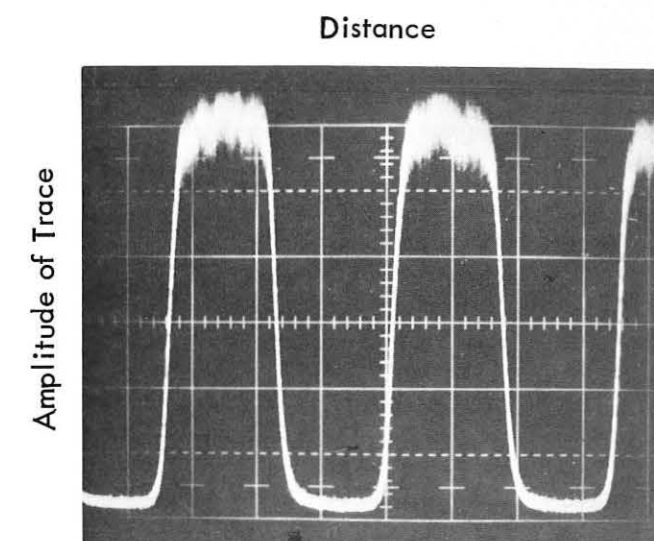

a) Spatial Frequency = 100 cycles/inch

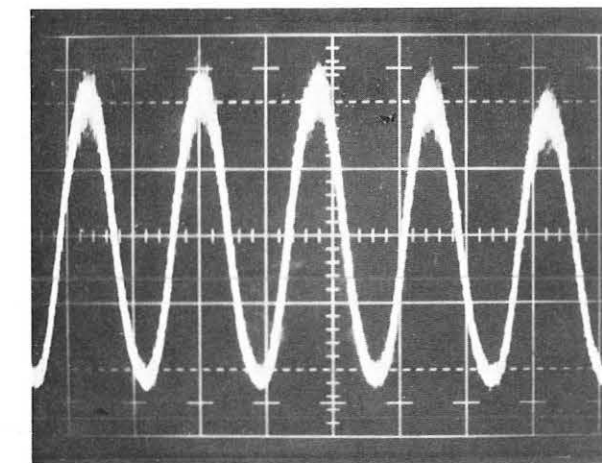

b) Spatial Frequency = 500 cycles/inch

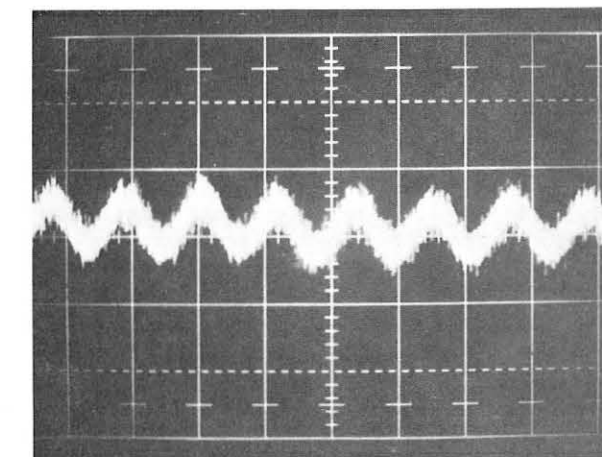

c) Spatial Frequency = 1500 cycles/inch

FIGURE 14: Square-Wave Response Measurements of Receiver CRT-Lens

with other types of targets which have a limited number of cycles, such as standard resolution targets with 3-bar or 5-bar groups at each spatial frequency. The availability and quality of the Ronchi rulings as square-wave targets as compared to sinusoidal targets is the principal advantage of this method over a direct measurement of the sinusoidal response.

Figure 14 shows typical oscilloscope traces obtained for the square-wave response of the receiver CRT and lens at spatial frequencies of 100, 500, and 1500 cycles/in. measured with a lens aperture of f -2.8 and a reduction ratio of 3 to 1. The square-wave responses of the receiver and scanner were measured over a range of lens apertures from f -2 to f -5.6 using a set of one-inch square rulings with spatial frequencies of 100, 200, 500, 1000, 1500 and 2000 cycles/in. At each aperture setting, the brightness of the CRT and the gain of the PMT were maintained constant and a trace of the response at each spatial frequency was photographed.

The square-wave response is normalized by dividing the response at each spatial frequency by the response as the frequency approaches zero. At low frequencies, the shape of the response closely approximates a square wave (see Figure 14a) and the amplitude approaches the zero frequency response. In our tests, the response at 100 cycles/in. was used to normalize the responses at higher frequencies, and the flat areas at the peaks of the trace assure that this amplitude is a true measure of the zero-frequency response.

The sinusoidal response of the CRT-lens combination is derived from its square-wave response by using their Fourier-series-relationship. The square-wave response, $R_{sq}(\omega)$, can be represented by the sinusoidal response, $R_{sin}(\omega)$, in the following familiar series:

$$R_{sq}(\omega) = \frac{4}{\pi} [R_{sin}(\omega) - \frac{1}{3} R_{sin}(3\omega) + \frac{1}{5} R_{sin}(5\omega) - \frac{1}{7} R_{sin}(7\omega) + \frac{1}{9} R_{sin}(9\omega) + \dots] \quad (14)$$

Through use of a similar series for each $-1/3R_{sq}(3\omega)$, $1/5R_{sq}(5\omega)$, $-1/7R_{sq}(7\omega)$, . . . and adding these algebraically to the above series, the following expression for the sinusoidal response can be verified:

$$R_{sin}(\omega) = \frac{\pi}{4} [R_{sq}(\omega) - \frac{1}{3} R_{sq}(3\omega) - \frac{1}{5} R_{sq}(5\omega) + \frac{1}{7} R_{sq}(7\omega) + \frac{1}{11} R_{sq}(11\omega) + \dots] \quad (15)$$

The result of these measurements on the scanner lens at an aperture of f -4 and a reduction ratio of 5.4 to 1 is shown as curve B in Figure 13.

Discussion of Measurements

A comparison of our results obtained from square-wave response measurements with those obtained from edge-response tests verifies that these methods produce reasonably consistent measurements. Curves A and B of Figure 13, for example, illustrate the correlation between typical results from the two methods on the same lens under identical conditions. Judging from experience with these measurements and their repeatability, we conclude that the MTF curves are most accurate in the response range from 0.8 to 0.3 and it is estimated that the response is accurate within ± 0.05 in this range. It is this middle range of response that is likely to be the most important area of the MTF curve in an analysis of the resolution limits of systems consisting of several cascaded elements.

As discussed in the second section, the resolution of a lens is dependent on many factors including the aperture, wavelength of the transmitted light, and the displacement from the optical axis. The effects of the aperture on the MTF of the scanner lens is illustrated by the curves in Figure 15. The

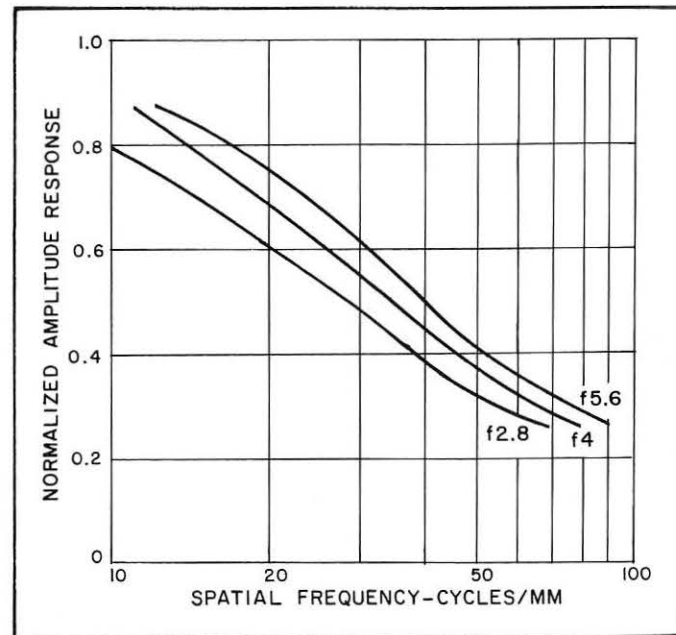

FIGURE 15: Variation of MTF with Lens Aperture.

theoretical limit of resolution increases for lower f -numbers, but this effect is more than offset by the aberrations caused by the increased lens diameter utilized for these f -numbers. The results indicate that over the range of apertures tested, maximum resolution is achieved at f -5.6, and this setting was selected for the scanner lens. The receiver lens resolution in Figure 1 is less critical than that of the scanner because it operates at a smaller reduction ratio; an aperture of f -2.8 is used to increase the exposure at the film.

The effect of the different spectral outputs of the P-11 and P-16 phosphors on the lens MTF is shown in Figure 16. These curves were derived from measurements on the same lens under identical conditions except that the P-11 CRT was used

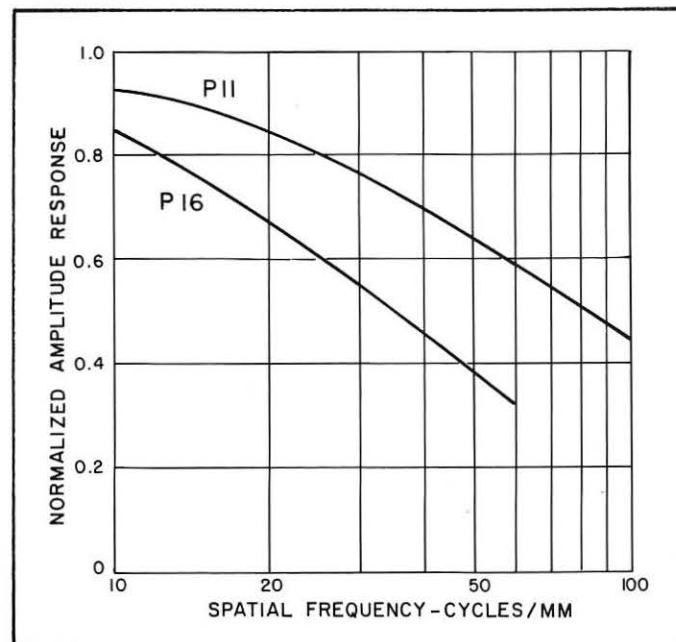

FIGURE 16: Effect of Wavelength on MTF of Scanner Lens at f -4.

as a light source for one measurement and the P-16 CRT was used for the other measurement. The Nikkor lens is corrected for the P-11 wavelength (4600 Å) and the near ultraviolet-light output of the P-16 (3700 Å) degrades the lens performance significantly. However, the P-16 phosphor is essential for the flying-spot scanner because of its vastly superior phosphor decay characteristics.

A comparison of the on-axis versus off-axis performance of the scanner lens is shown in Figure 17. The off-axis measurement was made at a viewing angle of eight degrees, measured from the optical axis which corresponds to the maximum angle required for viewing the corners of a 2.5-in. by 3.5-in. rectangular raster on the CRT with a 55-mm focal-length lens at a 5.4-to-1 reduction ratio. Within the accuracy of the measurements, the test results showed no essential differences in the lens MTF between one corner and another at the same viewing angle or between the horizontal and vertical scanning directions. The data from these measurements provide a quantitative basis for selecting the reduction ratio and aperture of the objective lenses.

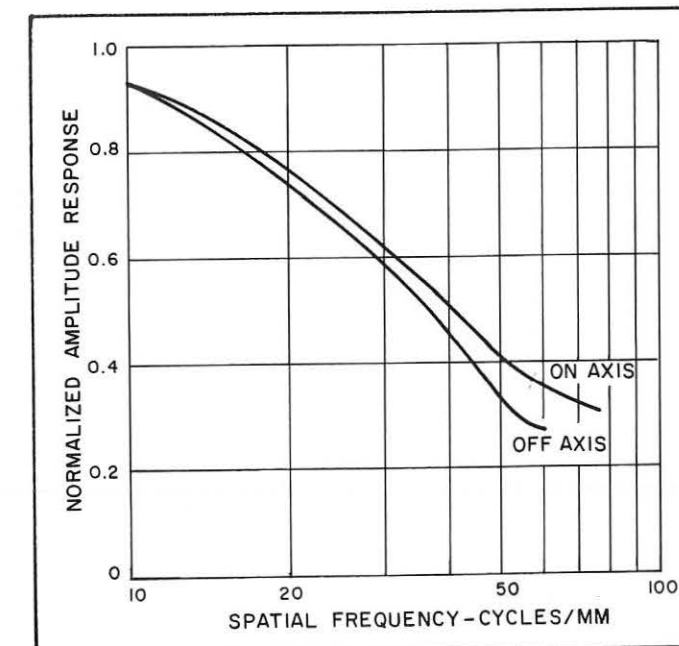

FIGURE 17: On-Axis and Off-Axis MTF of Scanner at f -5.6.

MODULATION TRANSFER FUNCTION APPLIED TO SYSTEMS ANALYSIS AND EVALUATION

The outstanding advantage of the modulation transfer function over other techniques for the evaluation of resolution is its applicability to a system consisting of several cascaded elements. Since system MTF is the product of the component MTF's, MTF plots with units of spatial frequency referred to a common plane reveal the influence of each component on system resolution.

In addition to the CRT and lens effects discussed above, the resolution of an image-transmission system is affected by the characteristics of the transmission channel. For a television or raster type of display, the spatial variation of the image intensity is the result of the time variation of the video signal. Thus, the time-frequency response of the video channel is related to the spatial-frequency response of the display. The equivalent MTF of the video channel is derived by dividing the time-frequency of the frequency-response function by the appropriate scan rate to convert from time frequency to spatial frequency. Because of its dependence on scan rate, the equivalent MTF is different for the horizontal and vertical directions of a raster-type display.

The experimental version of the image-transmission system

of Figure 1 transmits a single frame of approximately 4×10^6 picture elements over a 4.5-MHz channel in one-half second. With this transmission time, the 3.5-in. by 2.5-in. CRT raster requires a horizontal scan rate of 12,500 in./sec and a vertical scan rate of 7 in./sec. The time-frequency response of the video channel is assumed to be down 3 db at 4.5 MHz and to decline at a rate approaching 6 db per octave at higher frequencies. In the horizontal scanning direction, the 3-db point at 4.5 MHz corresponds to a spatial frequency of $4.5 \times 10^6 \div 12,500 = 360$ cycles/in. or 14.2 cycles/mm in the plane of the CRT, and the equivalent MTF passes through this point, as shown in Figure 18. In the vertical scanning direc-

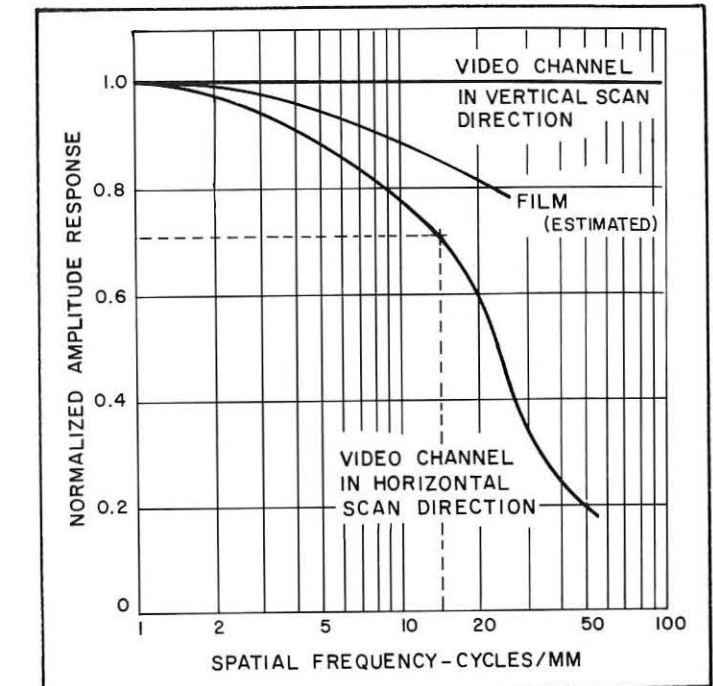

FIGURE 18: MTF of Video Channel and Receiver Film.

tion, the 3-db point occurs at a spatial frequency of $4.5 \times 10^6 \div 7$ in./sec. = 6.43×10^5 cycles/in., or 2.53×10^4 cycles/mm; the equivalent MTF is, therefore, essentially unity for the range of spatial frequencies under consideration.

The receiver camera in Figure 1 captures the CRT image from a single-frame scan on 35-mm film. Among the films tested thus far, Bell and Howell AHU microfilm, type 1K/400, provides the best combination of film speed and resolution for this application. Because the modulation-transfer-function concept is based on linear analysis, caution must be used when applying the MTF concept to photographic film. In general, film has a nonlinear response. In order to measure the response of the Bell and Howell film, test exposures were made of an unmodulated CRT raster over a range of beam currents and the resulting film densities were measured with a microdensitometer. It was found that with reduced development time a reasonably linear response of film density to video voltage could be achieved over a density range of approximately 0.25 to 1.2. Thus, the MTF concept is applicable in this range.

We have not included a study of MTF of Bell and Howell film in our work, to date. Rather, we have estimated its MTF by comparing it with a Kodak microfilm of comparable resolution. The estimated MTF of the Bell and Howell AHU film, based on the data for the comparable Kodak film, is shown in Figure 18. Note that the film frequency response is sufficiently better than the response of the other system components to make its degradation effect on system resolution negligible.

The input to the experimental system is a photo-image of a page of text on microfilm in an 11.72 mm x 16.5 mm format.

Obviously, the quality of this image directly affects the system output, and it is essential to obtain high-quality images of the textual inputs. The microfilming equipment used to photograph the text in this system provides a limiting resolution on the microfiche image of approximately 120 to 150 cycles/mm.

System MTF

Because the MTF of both the lens and the CRT's depend on position with respect to the optical axis, any evaluation of system resolution must be confined to a specific area of the image. For evaluation of the experimental system, complete measurements were taken at five different locations—the center and four corners of the CRT raster.

In Figure 19 the MTF of the system components are plotted for the vertical scanning direction at the center of the CRT

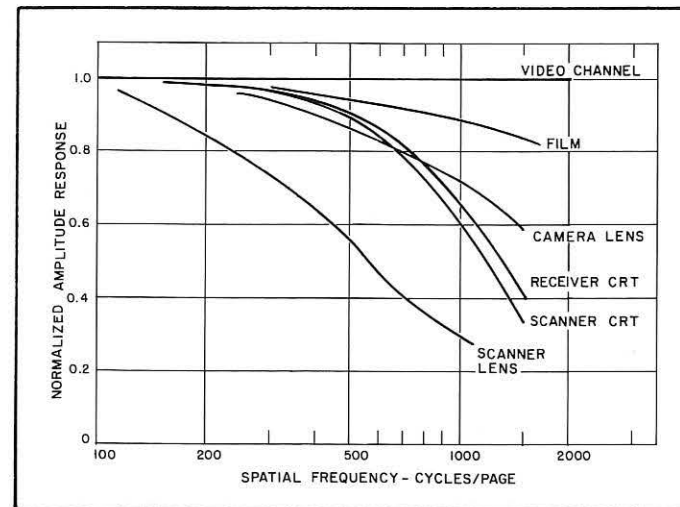

FIGURE 19: Component MTF's in Vertical Scanning Direction.

raster. One can convert the units of spatial frequency, cycles/page, to cycles/unit length for any location in the system by dividing by the vertical dimension of the page image at that location. For example, 165 cycles/page represents a spatial frequency of 10 cycles/mm in the plane of the microfiche when the page image has a vertical length of 16.5 mm.

The curve of the system MTF in the vertical direction at the center of the CRT raster is shown in Figure 20. If the limiting resolution is assumed to be the 3-percent response point, (a valid assumption based on our experience), the limiting reso-

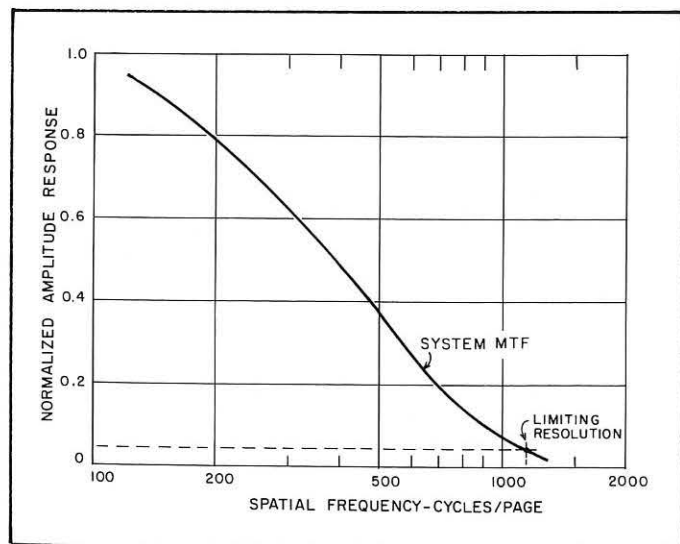

FIGURE 20: System MTF in Vertical Scanning Direction.

lution of the system is 1200 cycles/page. We have confirmed this number by transmitting standard 5-bar resolution targets through the system and examining an enlarged image of the resulting 35-mm film. Target groups with a spatial frequency of 70 cycles/mm, corresponding to 1150 cycles/page, have been resolved.

The horizontal scan lines of a raster are, in effect, spatial samples along the vertical-scan direction. In linear-system theory, the sampling theorem states that any signal whose highest frequency component is less than half the sampling rate can be faithfully reproduced from its sampled representation by passing the samples through an ideal low-pass filter that passes all frequency components of the original signal but rejects all frequencies above half the sampling rate. If either the original signal or the reproducing-filter response has components at frequencies exceeding half the sampling frequency, spurious components will be introduced in the reproduced signal.

In the system of Figure 1, the signal being sampled through raster scanning is, in effect, the vertical variation in film transmissivity of the original microfilm image convolved with the spread function of the scanner CRT-and-lens combination. In other words, the spatial-frequency spectrum of the signal being sampled is that of the original image, multiplied by the MTF's of the CRT and the lens. At the receiver the reproducing (desampling) filter is composed, in effect, of the combined MTF's of the receiver CRT and lens, the film, and the viewing optics, including the observer's eye. When the electro-optical system bandwidth is so broad that it has no influence on system response, the minimum number of scan lines per raster that should be employed is twice the highest frequency component in the microfilm image.

If it is assumed that the system MTF is sufficiently broad to pass the spatial-frequency spectrum required for reproducing a given class of images with acceptable quality, a sampling rate of twice the maximum frequency in that spectrum allows faithful reproduction of the spectrum components. If this sampling rate violates the sampling theorem applied to either the scanner or receiver, spurious components will exist in the reproduced image, but the reduced response of the scanner and receiver at high spatial frequencies attenuates the amplitude of these spurious components and reduces their effect on image quality.

If the spatial bandwidth of the receiver, viewing optics, and observer are sufficient to pass the sampling frequency, the individual scan lines will be perceptible in the reproduced image. The visibility of the scanning pattern in the reproduced image tends to reduce image quality and a higher scan rate may be required in order to reduce this effect to a tolerable level.

Thus, the minimum acceptable number of scan lines is determined from the highest among the following three: (1) twice the maximum frequency in the spatial-frequency spectrum of interest; (2) the lowest sampling rate at which the spurious components in the reproduced image are negligible; (3) the lowest sampling rate at which the scanning pattern in the observed image is not objectionable. These criteria involve subjective evaluations of image quality. In practice, one evaluates empirically their combined subjective effect by transmitting selected test images through the system at various numbers of scan lines.

The limiting resolution in the horizontal direction is reduced at the nominal scan rate of the experimental system because of the effects of phosphor decay and the limited bandwidth of the video channel. The 12,500 in./sec scan rate required for the half-second transmission per frame causes a considerable enlargement of the CRT spot, as discussed above. However, it is possible to utilize circuits in the video channel which compensate for these effects, and various techniques of video processing are currently being investigated.

Image Evaluations

A primary objective of the experimental system is to establish specifications for the system components required to provide acceptable textual images of technical documents at remote locations. Experiments have been conducted in which selected text was transmitted over the system with different system MTF and with different numbers of scan lines. The system MTF was varied by changing the *f*-number settings of the scanner and receiver lens. The horizontal scan rate was reduced to 1250 in./sec for these tests to avoid the effects of phosphor decay.

An attempt has been made to correlate subjective evaluations of the image quality with the system MTF in order to establish a quantitative measure of the system resolution requirements. Since texts of technical documents contain a relatively high proportion of mathematical symbols and small characters such as subscripts and super-scripts more stringent resolution requirements are needed for this class of text than for conventional text. Initial evaluations from these experiments indicate that a limiting resolution of 1000 cycles/page, and correspondingly, 2000 scan lines are required for transmission of a typical page from a technical journal microfilmed at an 18-to-1 reduction ratio. A two-column page with approximately 70 lines/column and an average of 8 to 10 words per line was chosen as a typical journal page.

Our tests have demonstrated the difficulty of definitive requirements for the resolution of an image-transmission system. The subjective measure of image quality is influenced by many factors in addition to resolution. These factors include contrast, information content of the image, graininess and noise content of the image, and so forth, and the effects of these variables must be isolated in order to establish the inherent relationship between resolution and image quality. Our plans call for further evaluations of acceptable image quality through analysis of user reactions to experiments with the image-transmission system. These experiments will be conducted as part of the Project Intrex experimental, computer-oriented library system.

ACKNOWLEDGEMENTS

The research reported in this paper was conducted at the Electronic Systems Laboratory, Massachusetts Institute of Technology, as part of Project Intrex and was supported through grants to Project Intrex from the Council on Library Resources, Inc., and the Carnegie Corporation.

We gratefully acknowledge the assistance of the ITEK Corporation in making available to us their computer program, called Fourier Analysis Program (FRAP), for use in the computations described in the edge-response measurements.

BIBLIOGRAPHY

1. Technical Report ASD-TDR-63-796, "High Resolution Cathode-Ray Tube Evaluation" — prepared by Data Corporation, Dayton, Ohio April, 1964.
2. Perrin, Fred H., "Methods of Appraising Photographic Systems" — Part I. Journal of the Society of Motion Picture and Television (SMPTE), March, 1960, Part II, Journal of SMPTE, April, 1960.
3. Schade, Otto H., "A Method of Measuring the Optical Sine-Wave Spatial Spectrum of Television Image Display Devices" — Journal of the Society of Motion Picture and Television Engineers, September, 1958.
4. Linfoot, E. H., "Fourier Methods in Optical Image Evaluation" — The Focal Press, 1964.
5. Attaya, W. I.; Brock, G. C.; et al. ITEK Corp., Technical Report No. AFAL-TR-66-343, "Study of Image-Evaluation Techniques" — November, 1966.
6. Franke, George, "Physical Optics in Photography" — The Focal Press, 1966.
7. Kingslake, Rudolf, "Applied Optics and Optical Engineering" — Volumes I-IV, Academic Press, 1965.
8. Brown, Carroll J., "Resolution of Flying-Spot Scanner Systems" — IEEE Spectrum, August, 1967.



Electronic Systems Laboratory.

J. FRANCIS REINTJES is Professor of Electrical Engineering at the Massachusetts Institute of Technology and Director of the Electronic Systems Laboratory, M.I.T. Currently he is the technical leader of the PROJECT INTREX research group in the



Mitre Corporation. In 1964, he joined the Electronic Systems Lab, M.I.T. and is currently involved in information-transfer experiments (Project INTREX).

DONALD R. KNUDSON received his S.B. and S.M. (EE) degrees from M.I.T. (1955). After military service, he worked on aircraft and machine tool controls followed by three years of operational analysis of command and control systems with the



reading machines at the General Electric Computer Laboratory in Palo Alto, development of remote graphical computer terminals for Project MAC and development of a remote text-access system for Project INTREX — the latter two as a member of the Electronic Systems Lab at M.I.T.

URI F. GRONEMANN received a B.S. degree from U. of Illinois in June, 1956, M.S. from Stanford U. in January, 1958 and Ph.D. from M.I.T. in January, 1964 — all in Electrical Engineering. His professional experience includes research on



Since May of 1966, he has been working on Project INTREX as a research engineer in the Electronic Systems Laboratory of M.I.T.

STEPHEN N. TEICHER received his S.B. degree from M.I.T. (1966). While an undergraduate at M.I.T. he worked in the Advance Design Engineering group of General Electric's Power Transformer Division as a Co-op Student.

M. E. D. I. A.

Man's Environments: Display Implications & Applications

10TH ANNUAL SYMPOSIUM

MAY 27, 28, 29, 1969

MARRIOTT TWIN BRIDGES MOTOR HOTEL
ARLINGTON, VIRGINIA

Information display technology extends man's senses to help him meet face to face with his fellow across the Earth, scrutinize a patch of dust on the moon, shepherd hurtling vehicles through space or along expressways, and peer into the depths of the atom or the sea.

Today, network television, eyes in satellites, and exploring machines are emphatic realities. Radar vision pierces the darkness and mist. Displays linked to computers or broadcast networks allow us to see and hear the men whose judgments and decisions are felt throughout the world.

This technology provides tools through which man can better understand himself and the universe in which he resides. Yet, these marvels do not yet bear, in their proper fashion, on many pressing needs of the present. Nor, does it seem that man has thus far conceived with any scope or depth the complexity of times to come.

Thus, the theme of the 10th Annual SID Symposium is M.E.D.I.A. This Symposium will consider man in his environments—natural and man-made—and the actual and probable improvements which can be engendered through the intelligent and imaginative application of information display technology.

The program schedule outlines the environments and their facets, anticipated developments, and display implications and applications. These subject areas are intended to promote thought and response in the form of contributed papers. The keynote address will set the theme, and a panel discussion will conclude the Symposium with a "Challenge" to the display technology participants.

TUESDAY, MAY 27, 1969

Keynote Address: MAN'S ENVIRONMENTS: Natural and Man-Made

Luncheon Speaker

MAN'S NATURAL ENVIRONMENT

Consider the utilization of display technology to serve these areas: agriculture and horticulture; forestry; geology; geophysics; geodesy; astronomy; and, oceanography.

Future Developments

Ecology & Conservation
Economic Development
Agriculture in America
Air & Water Pollution
Experimental Cities
Recreation Outdoors

Display Implications & Applications

Nature's Laboratory
Computer Time Sharing between Home & Business
Automation of Planting & Harvesting
Monitoring of the Total Atmosphere
Controlled Environment
Cultural Activities
Exhibitions
"Adventure" Playgrounds

Cocktails & Buffet Dinner

WEDNESDAY, MAY 28, 1969

MAN-MADE ENVIRONMENTS

Social Facet

Address society's needs and requirements as these relate to: research and practice of medical science; health and welfare; preventive medicine; legal science and law enforcement; cultural and religious aspects; economics and employment; and urban renewal.

Luncheon Speaker

Educational Facet

Providing for the learning levels of early learners, primary, secondary, university, and adults by offering educational opportunities such as academic and professional, vocational and agricultural, industrial and technical, leisure and recreational, and special types for mentally and physically handicapped.

Cocktails

Future Developments

Controlled Relaxation & Sleep
Choice of Sex of Unborn Children
Chemical Means to Improve Memory
Human Hibernation
Means for Surveillance & Control of Individuals
Automatic Voting from Individual Homes
Multiple-Use Dwellings

Future Developments

Man-Machine Training Devices
New Educational Techniques
TV Transmission via Phone
Rapid Language Teaching
Small Inexpensive TV Receivers
Home Education via Video Techniques

BANQUET SPEAKER

Display Implications & Applications

Multiple-Access Computers
Thought Projection
Therapeutic Activities
Controlled Mating
Electrode Insertions in the Brain
Behavior Manipulation
Human Engineering
Privacy

Display Implications & Applications

Three-dimensional Photography for Movies & TV
Computerized & Programmed Learning
Time-Shared Computers & TV University Cities
Specialized Institutions
Room Temperature Superconduction
Educational-Cultural Parks

THURSDAY, MAY 29, 1969

Transportation Facet

Moving people & vehicles to serve the needs of: inner-city, urban-suburban, regional (megalopolis to megalopolis), cross-country, cross-continent, and inter-continent.

Communications Facet

A communications medium or a combination of media should serve: urban & suburban societies, commercial & industrial operations, health & medical science, military & defense programs, educational & cultural activities, political processes (local, national, international), legal science & law enforcement, or recreational & leisure.

Display Implications & Applications

Hybrid Personal Vehicles
Tunneling
All-weather Requirements
Freight Handling
Shuttle Services
Signaling & Routine (including Sequencing of Vehicles & Passengers)

Future Developments

Wide-band Communications Systems
Vehicular Communications
Alternative Travel Routes
Microwave Power Transmission
"Sketchpad"
Diagnostics: Men & Machines
Universal Language

Future Developments

Highway Automation
Traffic Surveillance & Control
Off-Highway Vehicles
Rapid-Transit Automation
Air-Cushion Vehicles
VTOL Commercial Transportation
Supersonic Air Transport

Display Implications & Applications

Home Data Consoles
Navigation: Vehicle to Vehicle
"Armchair" Visiting
Business Conferences & Planning
Bio-Medical Telemetry
Remote Surgery
Automatic Translation Devices

"CHALLENGE" To Display Technology—Moderator & M.E.D.I.A. Panel

EXHIBIT HOURS: 9:00 a.m.-6:00 p.m.

M-O V for the short answer to high performance oscilloscope design

The short 900N & 1300Q with mesh p.d.a. extend MOV's range of C.R.T.'s. Both tubes give consistent high performance in compact rectangular design which makes them ideal for portable oscilloscopes employing solid-state circuitry.

Look at these features:

- Single gun mesh PDA
- High Sensitivity for solid-state circuitry
- High Brightness and writing speed
- Wide-band capabilities
- Alumined Screen
- 0.7W low wattage heater (900N)

	1300Q	900N
Scan size	4in × 2½in	2½in × 2in
Line width	0.014in.	0.012in.
Final Anode Voltage	7kV	6kV
Deflection Factor Dy	10V/in max	25V/in max
Dx	25V/in max	32V/in max
Overall length	13in.	8in.

For the new catalogue with full specifications of these and other M-OV cathode ray tubes write to:

Genalex
THE M-O VALVE CO. LTD.

Principal U.S. Distributor: Metropolitan Overseas Supply Corporation,
468 Park Avenue South, New York 10016 Area 212 Phone: Murray Hill 6-2120
Also area representatives in most major centers

M-O V MESH P.D.A. TUBES

Call for Papers . . .

Society for Information Display, M.E.D.I.A. Symposium, Washington, D.C. May 27-29, 1969. M.E.D.I.A. (Man's Environments: Display Implications & Applications). Tutorial and research papers are solicited. Papers should (a) identify specific aspects of man's environments in which Information Display Technology can produce vital benefits and (b) consider the actual and probable improvements which can be engendered through the intelligent and imaginative applications of Information Display Technology. Five draft copies and five copies of a 100-150 word abstract are due before December 15, 1968. Submit to: H. T. Darracott, 3325 Mansfield Road, Falls Church, Virginia 22041.

PLAN TO ATTEND M.E.D.I.A.
At The
MARRIOTT TWIN BRIDGES
MOTOR HOTEL
in
ARLINGTON, VA.

Special Rates for M.E.D.I.A.
&
Family Weekend Plans



William Emery, left, Marriott Hotel Convention Manager, and Lewis BLAIR, MEDIA Symposium Chairman, review facility plans for exhibits and meetings.

ID Readout

NEW CRT

Gordon R. Spencer, a Raytheon Company engineer, is the inventor of an improved cathode ray tube with high angular resolution characteristics under a recent patent assigned to the company.

The tube uses a segmented target and is applicable to such systems as sonar and numerical machine tool control equipment, which requires precise angular resolution.

With Raytheon since 1960, Mr. Spencer is manager of cathode ray engineering for the company's Industrial Components Operation in Quincy, Mass. He is responsible for research and development in the fields of storage tubes and cathode ray tube applications.

He has 20 years' experience in electronics including industrial and academic positions, and holds three other U.S. patents for electron gun designs. He has presented professional papers at the Institute of Electrical and Electronics Engineers, American Society for Testing and Materials, and the National Tube Techniques conferences.

TV MONITORS FOR NIGHT VISION

Hughes Aircraft Co. has awarded a contract to Conrac Corp. for television monitors to be used in a night vision system for combat helicopters. The Culver City aerospace systems manufacturer ordered 20 8-inch-screen and 10 14-inch-screen militarized monitors, at a contract amount of approximately \$225,000. The monitors will be produced by the Instrument/Controls Division of Conrac Corp., Duarte, Calif. Calif.

The INFANT system will provide bright, clear images of the terrain under low light level (night) conditions as a crew aid in target acquisition, weapon fire control, takeoff, navigation, formation flying, terrain avoidance, and landing.

Under the present contract ten aircraft are to be equipped: each with two 8-inch and one 14-inch monitor.

COMPUTER-DISPLAY LINK

An electronic display system which enables sales agents to process airline passenger reservations faster than before possible has been put into operation by Pan American World Airways.

In addition to its speed, the new link provides passengers with more efficient use of Pan Am's reservations services, Norman P. Blake, Senior Vice President-Traffic and Sales, said.

Developed jointly by Pan Am and Stromberg Datagraphics, Inc., of San Diego, subsidiary of General Dynamics, the new linkage is a forerunner of more sophisticated reservations and ticket handling equipment being built for air travelers flying future generation aircraft, such as the 366-passenger Boeing 747 Superjet.

The new display links the sales agent directly with PANAMAC, Pan Am's worldwide electronic reservations complex which serves 161 cities on six continents. In sales offices equipped with the new system, agents can further probe PANAMAC's memory banks to make reservations, retrieve sales records, obtain information on flight schedules and perform other passenger reservations services.

An initial \$1.3 million contract calls for delivery by Stromberg Datagraphics of 57 desk top displays, called SD 1110s, and associated control units which are being put into operation at the airline's headquarters reservations office in the Pan Am Building, New York.

Pan Am is the first airline to order the SD 1110. Mr. Blake said the SD 1110 units are being integrated into the PANAMAC system, which now uses agent sets utilizing

NEW, high visibility alphanumeric readout

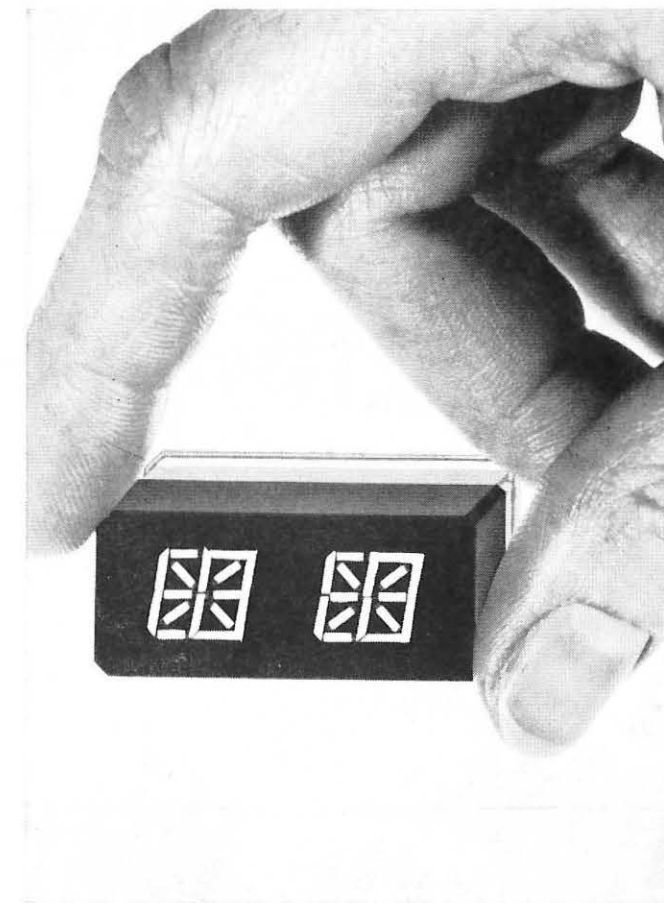

The 16-segment bar configuration of this new Tung-Sol readout, provides a potential of 65000 letter/symbol displays. This unit offers the same high visibility, clarity and sharp angle viewing that characterizes the Tung-Sol digital readout.



In addition to full alphanumeric display, fixed letter/symbol messages may be displayed in selected digit areas.

This new readout is compatible with the standard Tung-Sol digital unit. Use of the same lamp banks, voltages and mounting techniques, permits intermixing the readout blocks.

Write for detailed technical information. Tung-Sol Division, Wagner Electric Corporation, One Summer Ave., Newark, N. J. 07104.

TUNG-SOL®
ALPHANUMERIC READOUT

© REG. T.M., WAGNER ELECTRIC CORPORATION

Circle Reader Service Card No. 18

Here's the new standard for high power deflection amplifiers:

± 60 volts 120 volts total
 ± 50 amps 100 amps peak-to-peak
 Small Signal Bandwidth ... 600 kc

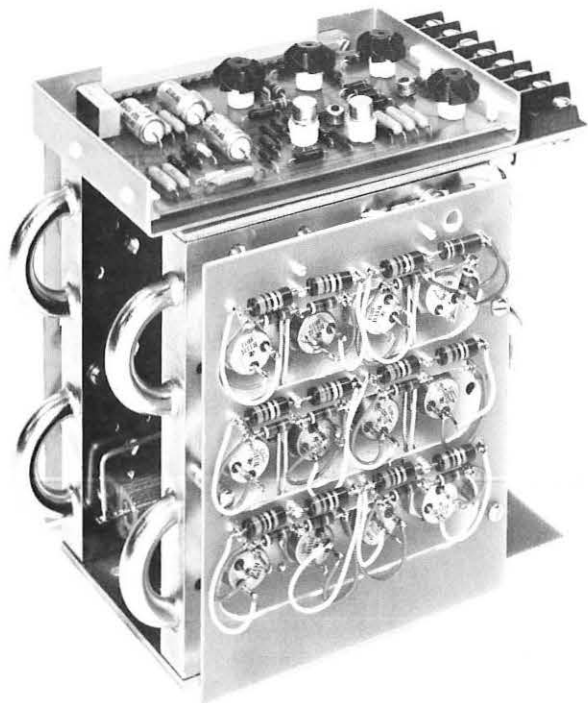

Model 1069-02
 Deflection Amplifier

Like the other 1069 series amplifiers, the 1069-02 is dc coupled and particularly well suited for high speed random deflection systems.

Typically, the 1069-02 will move a cathode ray tube spot through 42° in 4μs when the tube is operated at 25 kv.

Litton deflection amplifiers are supplied with super-regulated power supplies and integral cooling systems.

Need more information? Call us at (415) 591-8411 or write to Litton Industries Electron Tube Division, 960 Industrial Road, San Carlos, California 94070.



electric typewriters to process passenger reservations. He explained that the Stromberg Datagraphics units will not replace existing agent sets, but are being phased into the PANAMAC network as the system is expanded.

The heart of the SD 1110 is Stromberg Datagraphics' CHARACTRON shaped-beam tube, a television-like tube capable of generating alphanumeric images containing over 1,000 typewriter-sharp letters and numbers.

Connected to PANAMAC's central computer by commercial telephone lines, an SD 1110 can transmit or receive data at the rate of 300 characters per second. The electric typewriters are limited to 11 characters per second.

INSTITUTE OF LIVING DEMONSTRATES ELECTRONIC SYSTEM AT APA MEETING

The Institute of Living, Hartford, Conn., one of the nation's outstanding teaching and treatment hospitals, demonstrated its on-line electronic hospital system at the American Psychiatric Association's meeting held recently.

The display features new on-line electronic CRT visual display units connected to the Institute's computer in Hartford. Through the use of these terminals, which are located at many different stations within the hospital, doctors, nurses, and Institute personnel can check patient status, hospital census, new admissions and discharges, bed availability and other information relative to patient care.

Called the Automated Master Patient Record System, it was designed primarily to free doctors and nurses from paperwork so that their time could be more usefully applied to caring for the patients. The system uses terminals supplied by the Bunker-Ramo Corporation of Stamford, Connecticut. From these terminals, various information on patients can be entered into the system so that doctors and other personnel can check the status of their patients at any time of the day from anywhere in the hospital.

This system represents one of the most advanced applications of computers to patient care, and was developed by a computer project team under the direction of Dr. Bernard C. Glueck, Jr., Director of Research, under a grant sponsored by the National Institution of Mental Health.

VERSATILE DISPLAY CONTROL UNIT DEVELOPED BY A. B. DICK COMPANY

An information display control unit—compatible with both closed-circuit television and computer data processing systems—has been developed by A. B. Dick Company. The versatile unit, a solid-state character generator using the latest in integrated circuit technology, provides the electronic link between the computer and the CCTV system.

Known as the Videograph Series 990, the unit provides high-resolution alphanumeric video display that is crisp and bright. This high resolution is achieved through use of an 11-by-9-dot matrix for character formation, which results in 22-line resolution due to interlaced scanning. The unit accepts ASCII binary-encoded 8-bit data from a variety of digital sources.

The 990 display control accepts ASCII input and generates an EIA compatible video signal. The unit's storage is magnetic-core. The refresh rate of 60 cycles per second assures flicker-free image. One display format is 16 lines of 32 characters. A cursor indicates the point of entry for data on the CRT. When positioned over a character image, entry of the new character replaces the old and the cursor is stepped to the adjacent right-hand character. The cursor may be selectively moved forward, backwards, up, down, to the start of the next line or returned to the upper left-hand corner of the CRT.

Where do you go from leadership in software?

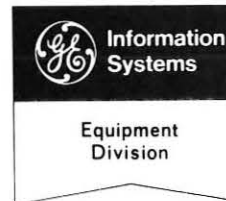

Up, if you're with GE's new Information Systems Group in Phoenix. With a solid head-start on the rest of the industry. Provided by our

GECOS III—the only operating system available today that integrates on-line and remote batch processing with time-sharing in a single three-dimensional system. And backed up by advanced hardware concepts in everything from remote terminals to third-generation processors.

It's what you'd expect from an organization that's increased worldwide shipments by 600% in 3 years. And increased its global lead in time-sharing via extended product lines and services.

Operation '68—Phase Two

It stands to reason that 32,000 people with that kind of momentum won't stand still. So, coming out of an encouraging first-half, we're setting our sights higher. Which is where you come in. Into a world-

wide computer operation still relatively young (under 4 years). With plenty of room to grow. And, high upward visibility.

Variety in 57 Languages. Plus.

Considering GE computer systems are installed or on order in a host of countries around the world, the diversity and depth of our assignments is no surprise. New applications virtually every day. Not to mention new wrinkles on existing ones. And the key to it all—system design responsibility—rests right here in Phoenix. So why not come out to Phoenix (the valley of the sun) yourself? And stake out your future in one of more of the following areas:

Programming Analysts

Analysis and design of automatic programming aids such as compilers, assemblers, sort-merge generators, operating systems. Flow chart, code, test and document systems software. Should have experience in two or more of the following: development of compilers, operating systems, utility routines, machine or assembly language programming, applica-

tions programming on medium to large-scale computer systems. Degree or equivalent.

Systems Applications Analysts

Design development of banking applications (specifically DDA, savings, installment loans) for small and medium scale systems. Should have 4 or more years experience with banking or applicable business programs. Degree or equivalent.

Systems Engineers

Hardware/software design of medium to large-scale digital computer systems for a broad spectrum of applications, including peripheral and central processor system design for input/output and memory control, etc. Specification analysis and design data communications systems for computer-to-computer and computer-to-user interfacing. BS or MS in EE or ME required.

Please send an informal resume to Mr. George Callender, Information Systems Equipment Division, Room 98-J, General Electric Company, 13430 N. Black Canyon Highway, Phoenix, Arizona 85029.



An equal opportunity employer M/F

THE SOCIETY FOR INFORMATION DISPLAY

ANNOUNCES A NEW
QUARTERLY PUBLICATION

PROCEEDINGS OF THE SOCIETY FOR INFORMATION DISPLAY

AVAILABLE AT NO COST
ONLY TO SID MEMBERS

The first issue will coincide with the 1968 Fall Joint Computer Conference and will commemorate the association of the *SID* with the American Federation of Information Processing Societies. Members of the *SID* will receive copies by mail.

Inquiries from non-members and institutions should be directed to:

WESTERN PERIODICALS COMPANY
13000 Raymer Street
North Hollywood, California

OCR TYPE FONT PROPOSED

The General Electric Co has proposed a tested and economical optical character recognition (OCR) type font as a United States standard.

The type font—or type shade which allows human recognition of characters read by a computer system—is the previously proprietary General Electric COC-5 (Coded Optical Character 5-bar code). When installed in a document handler, the COC-5 system permits users to print and re-enter computer information on a variety of documents intended for turn-around usage, without the need for special additional peripheral equipment.



The COC-5 has been tested for over two years on GE-200 and GE-400 line computer systems, and was proven to be up to five times more economical than similar systems. It has permitted operation at more than twice the reading and sorting speed of most optical-type, reader-sorter systems. The COC-5 can be read at speeds of 1,200 documents per minute and printed out at 1,200 lines per minute.

The COC-5 technique was originally developed for use with the MICR (Magnetic Ink Character Recognition) system, which was also developed by GE and introduced to the banking industry in 1958. GE's MICR was accepted as a U.S. standard in 1963. MICR characters are now found on bank checks, deposit slips and other turn-around documents.

Designed to supplement the E13B font used with the MICR technique, COC-5 and MICR document handlers, in combination, permit reading of records both optically and magnetically.

SENSING TECHNIQUE EXPLOITS MAN'S SQUARE DESIGN

Man, compared with nature, is a "square." At least he's square when it comes to his designs. Man-made objects have geometric lines, patterns, and square corners while most of nature's designs have curves, irregularities, and no corners. These square corners in man-made objects are the key to a new technique of pattern recognition now being studied by the Sensor Systems Laboratory of the Systems Group of TRW Inc.

Sensor systems scientist Dr. Gabriel Lowitz has taken a

new look at an old sensing device, the optical slit. He has come up with a technique which could have military, industrial, and scientific applications. By scanning a moving background with an optical slit fitted with a photosensing device, Dr. Lowitz has found that electronic signatures resulted when the slit passed over a regular object with corners.

An optical slit is a thin opening a few thousandths of an inch wide. Its most familiar use is in strip photography for aerial mapping where the image is painted line by line on the film through the optical slit.

Presumably, one application of the sensing device would be the examination of aerial photographs to detect man-made objects or possible military targets. In reconnaissance operations, thousands of aerial photos are taken and each must be inspected for significant data.

Employing the slit image corner detection, thousands of feet of film could be "quick-scanned" by an automatic processing system which would alert the operator whenever the sharp-cornered man-made object appeared. Then only a few selected frames would require close examination.

In industrial applications, the detection technique could be employed to automatically read alpha-numeric computer characters and other graphical data.

Dr. Lowitz believes the technique could be adapted to existing line sensor systems such as TV, infrared, or radar for "real time" detection.

First investigations of the slit image technique began as part of a company funded research program in the Sensor Systems Laboratory at TRW Systems Group. However, the U.S. Army Weapons Command, (AMSWE-RDR), Rock Island, Ill., has become interested in the detection scheme and has awarded TRW a contract to continue further studies.

FIVE BY FIVE

A large screen projection system that displays high-speed computer information on a 5 x 5 foot viewing area was demonstrated by Sanders Associates, Inc. at the Spring Joint Computer Conference. The system is designed for application in air traffic control, simulation and training, weather plotting, command and control, and related areas.

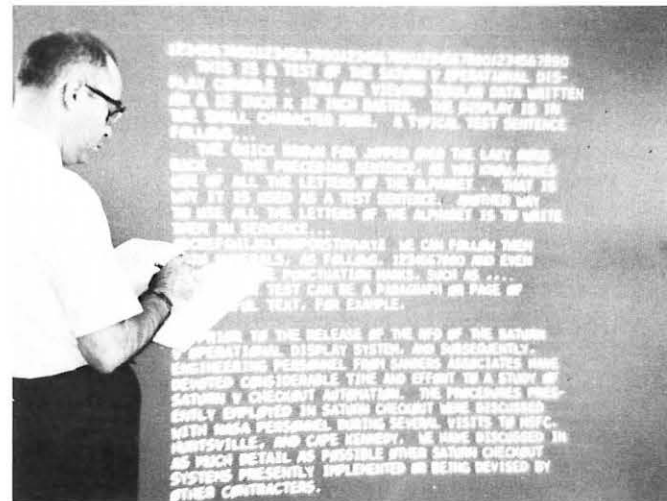

Designated the Sanders 980* Real Time Projection Display System, it can operate with either a front or rear projection screen. Any computer-generated data displayed on the system's five-inch CRT, such as vectors, characters, numbers, symbols, television or radar, are projected simultaneously on the large screen. When used in combination with a slide projector, it enables rapidly changing (real time) information to be displayed simultaneously with a fixed slide format.

Here's what Video Color offers:



TECHNICAL ABILITY

For any special purpose Cathode Ray Tubes

THIN TUBES

Monochrome and Two Color Flat Tubes

ULTRAHIGH RESOLUTION

(Less than .0005" spot size)

FIBER OPTIC FACES

HIGH CONTRAST

Special Ultrathin glass substrates to eliminate halation
Projection Tubes—Ultra High Light Output

SPECIAL SCREENS

Any Phosphor
High uniformity, Ultra Smooth Texture
Low Screen Noise
High Light Output

SPECIAL ELECTRON OPTICS

High Deflection Sensitivity
High Beam Currents
Multiguns
High Voltages

SPECIAL GEOMETRICS

Back Ported Tubes
Special Deflection Angles

SPECIAL GLASS STRUCTURES

Internal Targets

FULL LINE OF STANDARD TYPES CRT's FOR —

Character Generators (Monoscopes, etc.)
Readouts, Printers, Oscilloscopes, Radar,
Monitors, Video Recorders, View Finders,
Flying Spot Scanners, Back Ported Devices,
Computers, etc.

Video Color Corporation

Subsidiary of DYNA RAY CORP.

500 S. Douglas St., El Segundo, California
Phone: 213 - 772-5251 90245

match makers:

what's the best
interactive display
to mate with any of these?

UNIVAC 1108

IBM 360

Sigma 7

DDP 516

or any digital CPU

answer: **IDIOM**



IDIOM??? Yes. A lot of people think so; not only because of its low cost.

Programming convenience and versatility of use are what count most to experienced computer users. And IDIOM's design features a unique balance and coordination of hardware and software functions, an advanced Display Processing Unit and other design concepts that give you optimum convenience and versatility.

See for yourself. We'll send you an objective comparison chart detailing the specs for all standard interactive displays.

We're betting you'll agree that IDIOM is the answer.

IDI INFORMATION DISPLAYS, INC.
333 North Bedford Road
Mount Kisco, N. Y. 10549
(914) 241-1000 TWX-710-571-2179

HYBRID-DIGITAL X-Y PLOTTER

The world's first hybrid-digital X-Y plotter was introduced by Electronic Associates, Inc., at the Spring Joint Computer Conference. It is also the fastest plotter of its kind in the world, according to the co.

Called the EAI Series 430 DATAPLOTTER, the system features digital input and control, and an analog drive system for the plotting arm and pen. The unit thus combines the

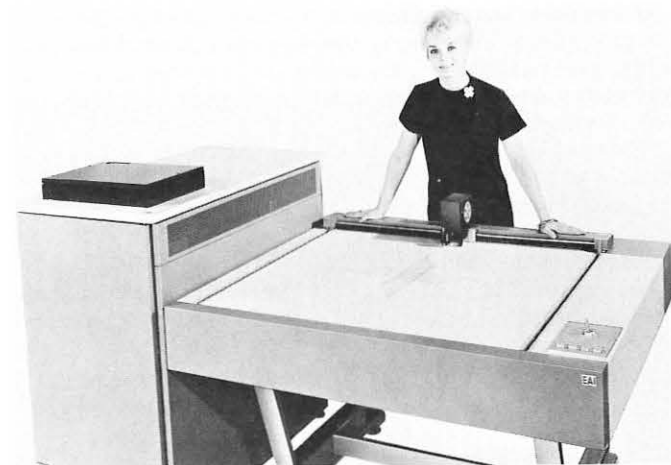

accuracy of digital techniques and the speed of analog in its hybrid operation. It plots non-segmented straight lines and curves over a 30" x 30" surface, and is the only plotter available that controls and maintains its own optimum, variable, operating speed.

Digital input signals to the 430 are converted to analog signals for high speed drive of the plotter's arm and pen. The distance between any two points of a line to be plotted (up to 30 inches) are defined digitally, then continuous, single-stroke lines are plotted between the points at speeds up to 20 inches/second—accelerating between 0 to 250 inches per second/second.

The unit also features tight control over potential errors due to centrifugal force or overshoot. Maximum error over the 30" x 30" surface is .010" for both X and Y resolution is .002".

X and Y positions of the plotting pen, and curve radii are continuously determined by repetitive solutions of third-order differential equations. Servo motors then drive the arm and pen smoothly to connect two data points with either a straight line or curved line having a pre-calculated radius. The variable velocity is also calculated continuously to be commensurate with the curvature or straightness of the line.

The Series 430 DATAPLOTTER can be fed from seven or nine track mag tape, with densities up to 800 bits per inch. The data is actually plotted in straight or curved line segments—but the movement of the pen isn't stopped at the end of each segment. As it approaches the completion of one line, it is receiving the end point of the next. In effect, the pen and arm of the plotter continuously track their instructions—resulting in smooth, continuous plots at high speed.

FORTLAN subroutines are provided for each of the 430's six operating modes; i.e., Line, Free Run, Curve, Print, Point and Scribe. A special utility package is also available which enables the user to draw grid lines, circles, ellipses, etc. The 430 can be used with any digital computer which has a FORTRAN Compiler—including IBM 360, CDC 600 Series, EAI 8400 Series and others.

Printing is accomplished by EAI's optional 48-character symbol printer, which annotates the plot with up to 350 alphanumeric characters per minute.

Business News

CONRAC CORP., N.Y., has won the electronic industry's largest production order for "private label" information display devices under a \$7 million contract. The company will deliver an undisclosed number of on-line computer data display terminals to BURROUGHS CORP. over the next three years . . . WESTGATE DIV. of ARVIN SYSTEMS INC., Dayton, Ohio, has delivered the first of four X-Y plotters to CONDUCTRON-MISSOURI for use in the C-5A aircraft flight trainer. The 30" x 30" X-Y plotters map out the simulated flight path on the C-5A during a regular training mission . . . DISCON CORP., Ft. Lauderdale, has won a \$110,000 contract from the Navy for design and development of an electronic message display system. System can simultaneously display up to 240 characters, with letters, numbers, and symbols being formed by a pattern of micro-miniature incandescent lamps.

ELECTRONIC MEMORIES INC., Hawthorne, recently announced a 30% price reduction for its Micromemory 1000 Core Memory System. In addition, the co. is introducing a 1,024 words x 8 bit version to complement the existing 4,096 words x 8 bit model . . . AIR CANADA has ordered \$10 million worth of digital information display systems from RAYTHEON CO. A total of 1800 television-like displays, the DIDS-400, will be installed in 47 cities served by Air Canada . . . INFORMATION DYNAMICS CORP., Reading, Mass., has won a \$75,000 contract from the Office of Education, Dept. of Health, Education and Welfare to conduct a study which will provide the library and information services community with an in-depth analysis and history of the experience of the Federal Government in automating library and information services.

NASA's Goddard Space Flight Center has awarded contracts to DATATRON INC., Santa Ana, totaling \$450,800. The firm will deliver over one hundred precision timing instruments during a six-month period. NASA will use the equipment to facilitate data reduction in its world-wide tracking stations for *Apollo* and *STADAN*.

MILGO ELECTRONIC CORP., Miami, has won a \$3/4 million contract from the U.S. Army Combat Developments Command Experimentation Command to develop and install a major expansion of the Data Acquisition and Recording System at the Hunter Liggett Military Reservation, Fort Ord . . . A \$201,192 order for direct view storage tubes to be used in military F-4 aircraft has been received by DU MONT ELECTRON TUBES, div. of FAIRCHILD CAMERA AND INSTRUMENT CORP. Contract was awarded by the Defense Supply Agency's Defense Electronics Supply Center in Dayton, Ohio.

The Chicago Center of MOTOROLA's government electronics div. has been awarded a contract for \$419,000 by the Air Force's Rome Air Development Center, to design and fabricate a development model of a small, lightweight modularized advanced radar indicator . . . The U.S. Army Map Service has awarded BUNKER-RAMO CORP. a contract to provide up to three computerized map-making systems for an amount not to exceed \$3,099,999. Total dollar value of the contract depends upon optional funding provisions that extend into 1970 . . . INFORMATION CONTROL CORP. has received a contract for two additional memory systems plus spares to be used in the TIPI Code Matrix Reader, total contract value estimated at approx. \$100,000.

The DELCO-REMY DIV. of GENERAL MOTORS, Anderson, Indiana, has ordered a digital drafting system to provide computerized drawings for use in an optical milling machine that cuts cams for electrical ignition systems. The system was introduced last year by the Graphic Systems Div. of COMPUTER INDUSTRIES INC., Van Nuys.

Be positive!

AS YOU IMPLEMENT AN INFORMATION SYSTEM

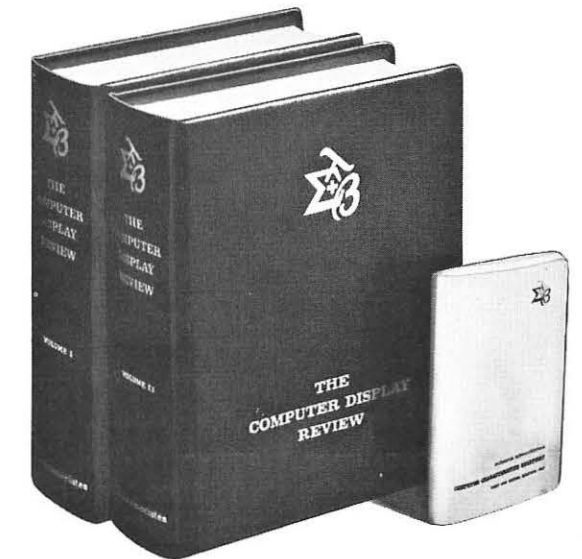

THE COMPUTER DISPLAY REVIEW

A unique service that provides a single source of technical and price information on computer-based alphanumeric, line-drawing and related display devices. In two volumes, (over 1,200 pages) which are updated three times a year, the REVIEW presents a precise, current and objective analysis of display hardware, software, applications and trends. Typically, the section on line-drawing display equipment contains seventy-five parameters and ten test results, amplified by extensive notes on salient features. Instruction repertoires are illustrated and software capabilities and limitations are described.

COMPUTER CHARACTERISTICS QUARTERLY

A pocket-sized reference, completely reissued four times a year, with the technical data needed to configure entire systems or compare hardware. In over 200 pages, the QUARTERLY provides comprehensive information on prices and operating characteristics both accurately and objectively.

Twenty-eight characteristics of more than 300 digital computers are tabulated. Over 800 peripherals, such as auxiliary storage and display units, with up to 16 characteristics per device, are listed. A where-used matrix shows all available standard interfaces linking processors and peripherals, regardless of manufacturer. Classifications of system configurations by price, central processors by application suitability, and internal storage characteristics by cycle time and bits per microsecond are provided.

Interested? You can't afford not to be. Please check the reader service card, or write to Mr. John Martell

adams associates

INCORPORATED

128 GREAT ROAD, BEDFORD, MASSACHUSETTS 01730

108 Water St., Watertown, Massachusetts 02172

THE KEY TO YOUR MAGNETIC SHIELDING Problems...



*Seamless tubing
construction*



Hydrogen annealing for maximum permeability



Customized fabrication to your exact engineering specifications



Fabrication in all types of MU metal materials including...

- Magnaloy
- Westinghouse Hypernik
- Hypernom
- Carpenter 49
- HY-MU 80
- Mu Metal



Ultimate in attenuation—60/—80 db

We have perfected the art of seamless-tube construction in magnetic shielding components at a price comparable to or lower than the "old-fashioned" overlapped welded seam designs

QUOTATIONS submitted on request per your blue print specifications for...

- ENGINEERING SAMPLES
- PROTOTYPES
- PRODUCTION RUNS

SEND FOR ILLUSTRATED BROCHURE

Magnetic RADIATION LABORATORIES, INC.
2475 West Devon Ave., Elk Grove Industrial Park
Elk Grove Village, Illinois 60007
Phone (Area Code 312) 9696

ID Products

Electronic Keyboards

Navigation Computer Corp., Norristown, Pa., manufactures the NAVCOR 1050 series keyboard assemblies. Completely modular in construction, the keyboards are available in a wide variety of standard configurations. Signals from the keys can be either brought out directly or coded to user requirements by a diode matrix. Standard keyboard configurations include alphanumeric models with up to 65 keys and numeric models with up to 16 keys.

Circle Reader Service Card No. 26

Stripchart Recorders

Stripchart recorders with integrated circuit electronics are produced by the Industrial Products div. of Texas Instruments Inc., Houston. The complete servo and signal electronics, except for zener reference circuitry, are on a single board.

Circle Reader Service Card No. 27

Display System Power Supply

Model 1584, manufactured by Power Designs Inc., Westbury, N.Y., is a regulated 1kV to 20 kVDC power supply for the operation of character generator or display CRT's and photomultiplier tubes. Extensive use of epoxy encapsulation permits environmental isolation and size reduction. The power supply is protected against overload or short circuit, the company reports.

Circle Reader Service Card No. 28

Miniature Incandescent Lamp

Precision Lamp Engineers, San Francisco, announces a 32 volt T-1 (.125-in. diam.) miniature incandescent lamp. It is available either based

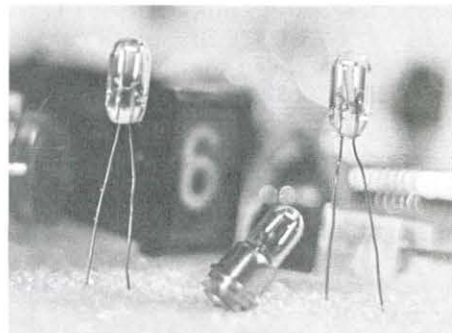

or unbased. The company reports that when operated at 32 volts, the lamp draws a current of 30 milliamperes, has a brightness of .200 candlepower, and has an average life expectancy of 5,000 hours. It is butt sealed to aid in tipless undistorted end viewing.

Circle Reader Service Card No. 29

Data Display Tube

Brimar Radio Valves & Tubes Ltd., London, England, designs a 12 in. data display tube for alpha-numerical and graphical displays. The rectangular tube can be used in keyboard terminal units for data links or computer interrogation.

Circle Reader Service Card No. 30

MAST

Random access 35 mm film loop projector



- 100, 200, 300 frame capacity
- choice of controls: dual dial, push buttons or computer
- 3.5 sec. max. to project any one of 100 frames
- 10"x15" rear projection daylight screen

Phone Collect 319-326-0141

MAST DEVELOPMENT COMPANY

ID-JA 2212 E. 12TH ST. DAVENPORT, IOWA 52803

Your Heart Fund Fights

HEART ATTACK
STROKE
HIGH BLOOD PRESSURE
INBORN HEART DEFECTS

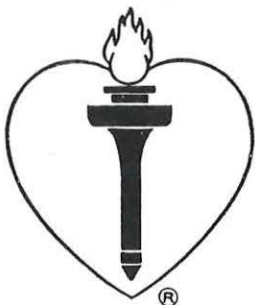

Illuminated Switch Assemblies

Electro-Mech Components Inc., San Gabriel, Calif., announces a new 2PDT Illuminated Push Button Switch assembly. Especially designed for the instrument and computer industry, it is available in both momentary and alternate action modes.

Circle Reader Service Card No. 32

UV Fiber Optics Faceplate

Mosaic Fabrication Div. of the Bendix Corp., Sturbridge, Mass., announces a line of faceplates for use in the near ultra-violet region of the spectrum. They are optically equivalent to a "zero thickness window" and are reported to have provided light gains of up to 50 times the intensity of previous lens systems. Applications are in direct-writing, high speed, data conversion systems which utilize ultra-violet imaging materials in the 200 to 400 nanometer range.

Circle Reader Service Card No. 33

Switch-Indicator

A switch-indicator manufactured by Bowmar Instrument Corp., Fort Wayne, Ind., is said to provide both visual readout and circuit continuities for control of remote digital computers and display devices. DC-3581 may be equipped with a variety of internal switching configurations for compatibility with BCD, 4-wire, 5-wire and other digital computer codes. The unit includes a backlit feature utilizing two 100,000-hour miniature high-reliability incandescent lamps in parallel behind the numeral being displayed.

Circle Reader Service Card No. 34

Illuminated Push-Button Switches

Marco-Oak, Anaheim, Calif., a div. of Oak Electro/Netics Corp., has introduced a series of momentary action illuminated push-button switches with independent lamp circuitry. SPST-NC/NO or SPDT configuration is available, depending on terminals selected. Switches are rated at 125 volts ac (28 volts dc), 3 amps resistive. Four basic types are offered including watertight and recess mounting models.

Circle Reader Service Card No. 35

High Voltage Power Supplies

Beta Instruments Corp., Newton Upper Falls, Mass., produces the Series HV modular High Voltage Power Supplies designed specifically for application in CRT display devices and systems. The units are all-silicon, solid-state with multiple outputs for connection to the anode, focus grid, G-2 and filament. According to the company, the supplies feature continuous short circuit protection, adjustable turn-on delay to permit filament warm-up and no overshoot on turn-on or turn-off.

Circle Reader Service Card No. 36

Portable Signal Generator

A portable, lightweight, FM signal generator, for VHF/UHF, CW/FM operation, is manufactured by Babcock Aerospace, Babcock Electronics Corp., Costa Mesa, Calif. Designated the BSG-23, the crystal-controlled unit is designed to test receivers, decoders, and components of command control, telemetry, and range systems in the 216 to 260 MHz and 400 to 550 MHz bands. A self-contained coder provides the BSG-23 with up to ten standard IRIG audio control tones, according to the company.

Circle Reader Service Card No. 37

Most major
computer makers
now use
Welch Allyn

FIBER OPTICS

In five years, we've made nearly a half million fiber optics units for computers, our own medical instruments, and other demanding applications. Many went into complete Welch Allyn systems, including our standard or special lamps. We have the creativity, the techniques, the production capacity. May we help you?

WELCH ALLYN, INC.,
Skaneateles Falls, N.Y. 13153 Telephone (315) 685-5788

WELCH ALLYN
Fiber Optics

XYZ Recorder

Spatial Data Systems Inc., Goleta, Calif., announces production of the XYZ Recorder, which allows the recording of XYZ data in 3-dimensions from analog voltage inputs. The system is reported to produce permanent 3-D graphs on light-weight, removable plotting boards. Initial uses projected for the unit include the recording of antenna patterns, surface temperatures, radar signatures and others.

Circle Reader Service Card No. 39

Cold Cathode Tube Display

A series of cold cathode tube decode display module assemblies are available from Integrated Circuit Electronics Inc., Waltham, Mass. The assemblies are sold ready for plug in panel mounting. The assembly includes bezel frame, readout tubes and electronics. The devices use all integrated circuit packages with TTL logic. According to the company, the units feature interchangeability with most other manufacturer's devices.

Circle Reader Service Card No. 40

Optical Encoder

The Renco Corp., Santa Barbara, Calif., manufactures an incremental encoder constructed of stainless and aluminum materials. According to the company, the encoder features modular construction, output connector, solid state electronics, precision bearings and glass code disc. It is available with a wide selection of standard output counts which are furnished in single and dual format with or without zero reference outputs.

Circle Reader Service Card No. 41

Plug-in, Alpha-Numeric Display Panels

A line of plug-in, alpha-numeric display panels for display applications ranging from small consoles to large wall systems has been announced by Ferranti-Packard Electric Ltd., Toronto, Canada.



Containing one to four, 10-module lines, with 2.7-inch-high characters, the display panels are claimed to have excellent wide-angle visibility and reflect light. Power is required only to change data. Operating speeds are 10, 15, 80 or 250 characters/second.

Interfacing to keyboards, tape readers, computers or via communication circuits is straightforward, with the units accepting serial or ASCII inputs directly. A standard unit can control up to 16, 80-module lines (1280 modules) and can be expanded to 20, 480 modules by plugging in additional address units.

Typical applications are arrival/departure displays for railroad or air terminals, advertising, status boards or computer-driven displays for operating rooms.

Circle Reader Service Card No. 42

Three-D Software System

California Computer Products Inc., Anaheim, Calif., leases a Three-D software system to allow a computer user to produce perspective drawings of surfaces. The company reports that the system allows the user to "walk around" a surface in successive drawings, generates a stereoscopic view of a surface and, with the CalComp Model 835 microfilm plotter, produce animated films automatically. Surfaces can be drawn opaque or transparent.

Circle Reader Service Card No. 43

Computer Graphics Terminal

Adage Inc., Boston, introduces its Model AGT/10 Adage Graphics Terminal. According to the company, features include a display of more than 4500 lines at 40 frames per second, and resolution of more than 100 lines per inch. The system provides for alphanumeric display with programmatic control of font and size. Applications include printed-circuit layout, signal analysis and mathematical modeling.

Circle Reader Service Card No. 44

"Twist Lens" Indicator Light

The "Twist Lens" indicator light, designed to use the T-1 3/4 Bi-Pin based lamp, is announced by Display Devices Inc., Los Angeles. The unit features front relamping, small panel area occupancy, minimum depth behind the panel, and high brightness when illuminated, the company claims. Regular T-1 3/4 lamp voltages from 6 to 28 volts are available.

Circle Reader Service Card No. 45

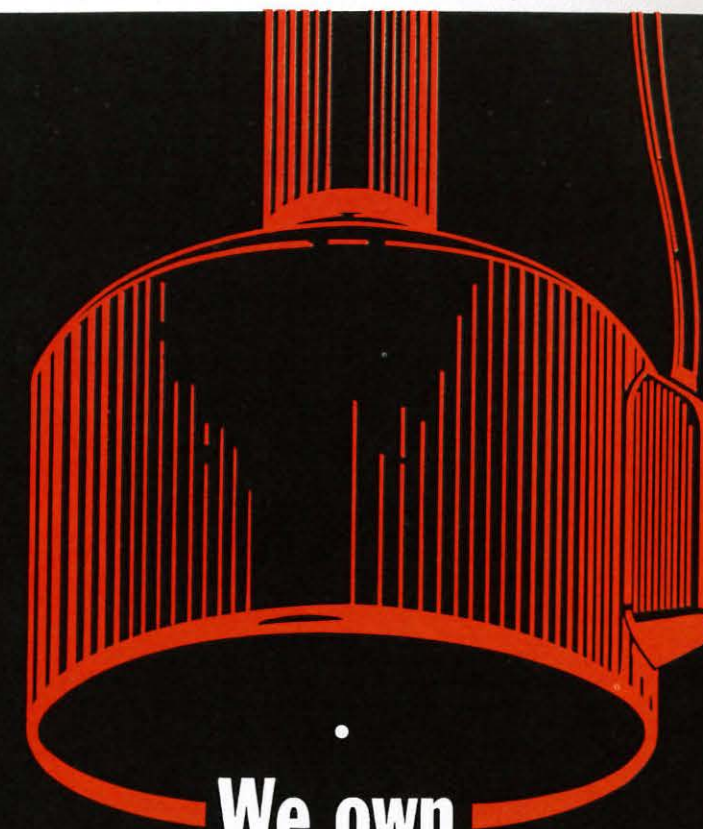

**We own
a small spot
in the CRT industry**

... as small as 0.00035"

Small spot size is only part of our story. This, combined with writing speeds up to 10¹⁰ inches/second, phosphor grain sizes as small as 1 micron and noise levels as low as 2% make Fairchild-Dumont's High Resolution Cathode Ray Tubes the industry standard.

Fairchild-Dumont's high resolution tube designs are now used in: • Side looking radar processing and recording • Atomic particle track scanning • Document scanning • Scanning of film recordings • Picture recording satellites • Infrared recording • Electrostatic printing • Character recognition • Computer controlled scanning and recording • Document storage and retrieval.

If you are a system designer involved in any of these applications, contact us to get the benefit of our wide product selection and depth of experience, or send today for our High Resolution Brochure HR-8.

WORLD'S LEADING MANUFACTURER OF DISPLAY TUBES

FAIRCHILD

DUMONT ELECTRON TUBES

A DIVISION OF FAIRCHILD CAMERA AND INSTRUMENT CORPORATION
750 BLOOMFIELD AVENUE • CLIFTON, N.J. 07015

NEW

*Cut down magnetic shielding
problems with new full line of
easy-to-use Netic Co-Netic Foils*

**In world-wide use for:
R & D • Prototypes • Evaluation • Production**

Valuable technical assistance to customers is a way of life with our engineers. Immediate delivery from stock in any length, in .002", .004", .006" and .010" thickness, and in any width up to 19 3/8". Standard widths are 4", 15" and 19 3/8". Full details in Catalog SG-1. Just ask for it.

WEST COAST STOCKING REPS

Tech Rep Distributor Co. Frauman Associates
10606 W. Pico Blvd. P.O. Box 969
Los Angeles, Calif. 90064 Menlo Park, Calif. 94026
213, 836-8806 • 213, 871-0055 415, 322-8461

MAGNETIC SHIELD DIVISION/Perfection Mica Company

1322 N. ELSTON AVE., CHICAGO, ILL. 60622...ORIGINATORS OF PERMANENTLY EFFECTIVE NETIC CO-NETIC MAGNETIC SHIELDING



on the move

LEONARD M. HANTMAN, director of technical operations for the past year, is now Technical vice president of Adams Associates, the Computer Consulting and Programming Div. of Keydata and Adams Associates Inc., Watertown, Mass.

THOMAS W. BURGESS has been appointed national sales manager for the Data Systems Div. of Sanders Associates Inc., Nashua, N.H.

WILLIAM L. KACIN is now vice president and general manager of Photomechanisms Div., Inc., subsidiary of LogEtrons Inc., Long Island.

An Information Systems Group has been established at Varian Associates, directed by THEODORE MORENO, Group vice president. The Group will initially include Varian Data Machines in Irvine, Calif.

Working from new Master Specialties Offices in the Netherlands, W. W. HENNINK will be responsible for sales and application services in Europe.

Two promotions announced by Beta Instrument Corp., Newton Upper Falls, Mass.: F. LEE WALKER is group leader in the Analog Engineering Group, and DAVID BROWN is group leader of the newly-formed Digital Engineering Department.

FRANK J. CUNNINGHAM is now vice president/marketing for the Defense Systems Div. of the Bunker-Ramo Corp., Canoga Park, Calif.

CHRISTOPHER M. PAFORT has joined Monitor Systems Inc., Fort Washington, Pa., as sales manager of the recently formed Computer Communications and Displays Div.



PAFORT



BRUCE

Appointed to the newly created post of director, marketing for Monsanto Company's Electronics Special Products group is CLARENCE R. BRUCE.

Named manager, instrumentation, for General Atronic Corp., Philadelphia, is GEORGE REVESZ. AL CANNON moves to the newly created post of marketing manager.

LEON WILLIAMSON, SID member, is Director of marketing for Digital Products Corp., Ft. Lauderdale, Fla.

LELAND H. AMAYA has been elected vice president/operations for Atar Computer Systems Inc., Los Angeles; LEONARD KLARICH is vice president/marketing, a new position.

FORDYCE M. BROWN, National SID treasurer, is now senior vice president of LogEtrons Inc., Springfield, Va. He remains as president of Photomechanisms Div., Inc., a subsidiary.

New Connecticut office of Programming Sciences Corp., N.Y., is headed by BARRY McADAM, previously manager of Technical Services at the home office.

In charge of all manufacturing, engineering and administrative functions at Honeywell's Data Products and Services Div. in San Diego is WINSTON R. WILLMERT.

United Data Processing has opened a Seattle branch and named WILLIAM A. BREALEY as director of marketing and branch manager.

Factsystem Inc., Chicago, has added eleven persons to the staff recently. They are: RICHARD PRESCOTT, systems director; CHUCK NEILSEN, programmer; NANCY OSTROM, programmer; MICHAEL REILLEY, programmer; KENNETH ZEMROWSKI, programmer; DAVID A. FAY, manager, Information Processing; JAMES J. STOODLEY, Operation Supervisor; DICK ENDERLE, Sales Representative; STANLEY GOSCH, manager, Marketing, Central Region; JACK HARDY, sales representative, and PAUL T. JENKINS, sales representative.

EDWARD MEAGHER is now serving as director of marketing for Amperex Electronic Corp., Great Neck, N.Y.

NEW MODULAR IMAGE SCANNING SYSTEMS

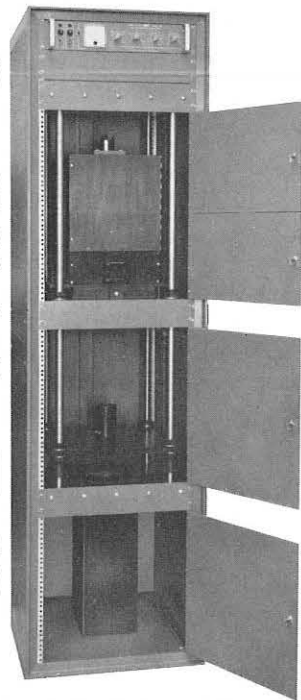

Now Kaye Scientific will custom tailor high resolution film or document scanners to meet specific requirements using newly developed standard interchangeable assemblies. High speed optics, 16 mm to 8½" x 14" formats, manual or automatic, fully aligned and ready to operate. Fast delivery and precision performance.

K KAYE SCIENTIFIC CORP.
533 Pacific Street, Stamford, Connecticut 06902 (203) 324-5741

WHAT'S NEW PUSSYCAT ?

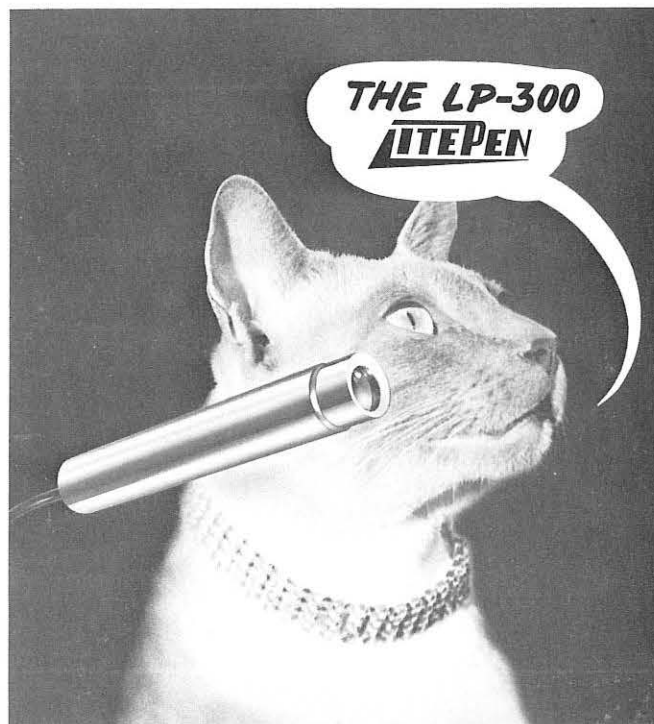

IC INFORMATION CONTROL CORPORATION
1320 EAST FRANKLIN AVE., EL SEGUNDO, CALIFORNIA 90245 / (213) 322-6930 / TWX (910) 348-6672

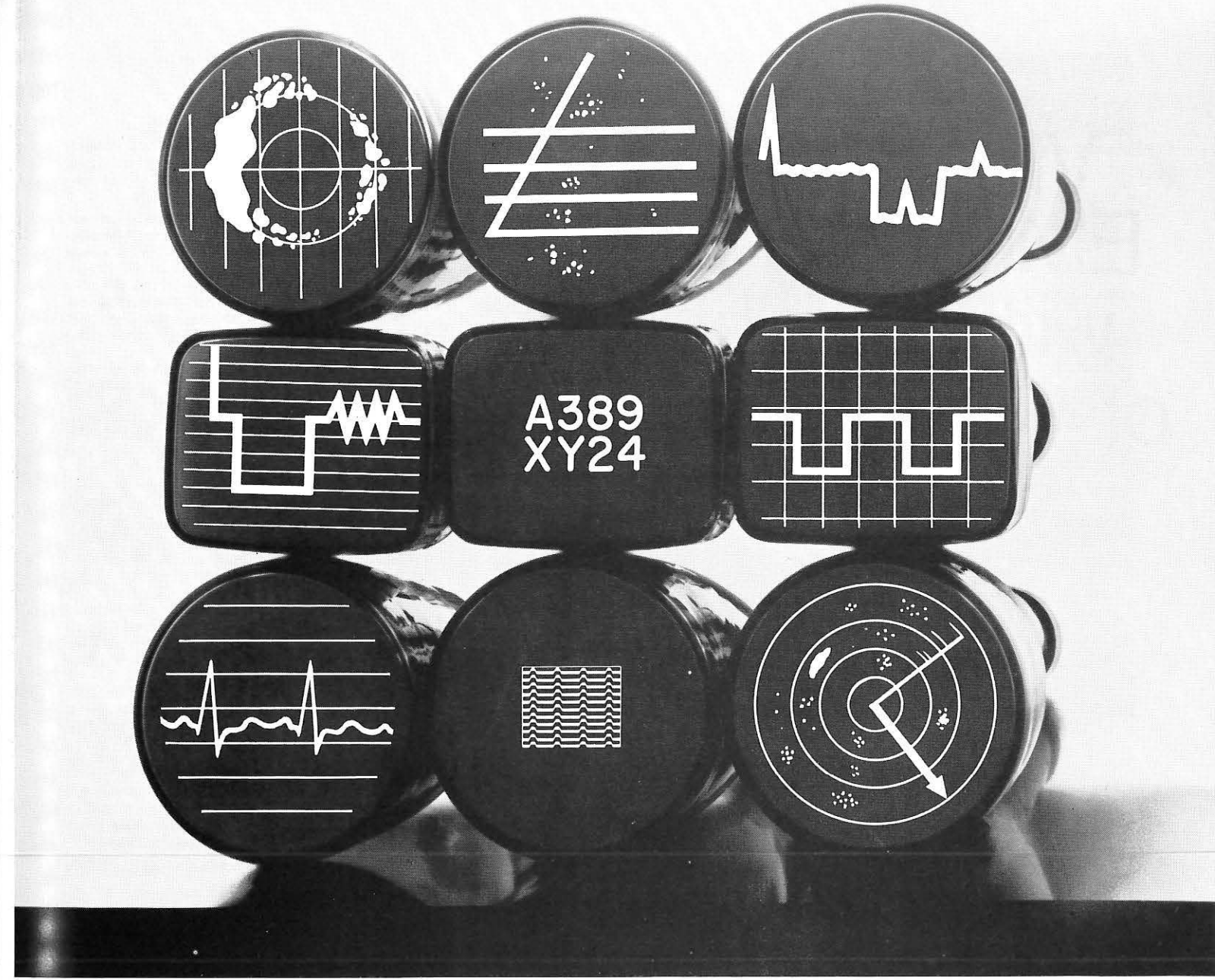

We offer over 200 talking pictures. Pick one that speaks your language.

Our CRT's have been articulate right from the start. Our first, thirty years ago, told us we were onto a good thing. Some people didn't believe it, but that one spoke our language.

Since then we've gone on to develop and produce CRT's that make up an electronic United Nations.

One speaks to the weather-

man. Another to a heart specialist. There's one that sits on a desk and talks to bookkeepers or accountants. And one that communicates with aircraft control tower personnel. One that strikes up a conversation with geologists. And even one that displays nuclear explosion data to anyone who cares.

That's asking a lot from a CRT.

But then we've always done that. And we'll go right on doing it. Because even as our customers tell us, there's almost no limit to what a CRT can talk about.

Want to start a conversation with a CRT? Call or write us to arrange a meeting... anytime.

Electronic Tube Division, **ETA** General Atronics, Philadelphia, Pennsylvania 19118



GENERAL ATRONICS

NEW VISIBLE LIGHT EMITTING DIODE with a brightness of 450 footlamberts

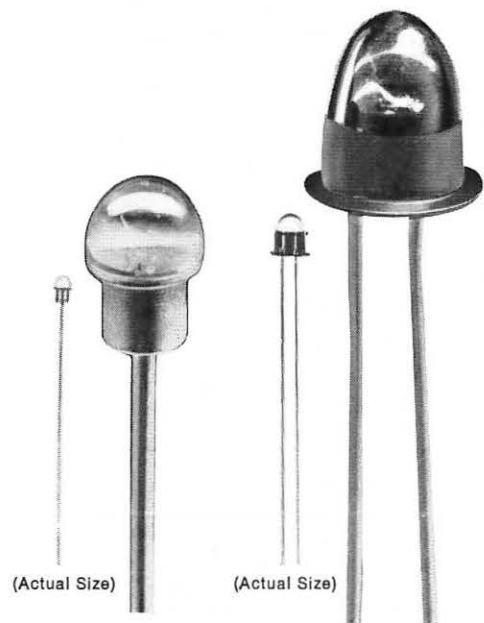

(Actual Size) (Actual Size)

	Model MV10A	Model MV10B
Forward bias ($I_f=50\text{ma}$)	1.65 volts	1.65 volts
On-off cycle time	10 nsec	10 nsec
Wavelength range	6500-7000Å	6500-7000Å
Brightness ($I_f=50\text{ma}$)	115-300 ftL	115-450 ftL
Price (in lots of 1000)	\$4.00 to \$18.00	

From film annotation to panel indicators, Monsanto's visible LEDs deliver solid state reliability, miniature size, low power consumption. And they're available off the shelf.

Other Monsanto Optoelectronic Devices

Infrared LED	M120B — 200 microwatts radiated power
	M120C — 1.5 milliwatts radiated power
Lasers	ML30C — 0.5 watts peak power output
Arrays	MA10A — alpha-numeric visible array

Monsanto

ELECTRONIC SPECIAL PRODUCTS

800 N. Lindbergh Blvd., St. Louis, Missouri 63166 / (314) 694-4639 or 4642

Interested in career opportunities? Send resumé to Manager Professional Recruiting. An equal opportunity employer.

Circle Reader Service Card No. 51

New Literature

Display System Brochure

An eight-page brochure on the Ferranti Argus Display System is available through the British firm's U.S. representative, Decision Services International, Inc., Boston, Mass.

The Argus System, which is used in the British Overseas Airways Corporation's BOADICEA System, is the first agent display system to be installed and operating for any major airline. Presently the system is operating in New York, with installations scheduled for Miami, Chicago, Los Angeles, San Francisco, Toronto, and Montreal, before the end of the year.

The brochure describes the complete Argus system, including the CRT display for both CRT and printer terminals.

Circle Reader Service Card No. 52

Data Sheet

Oppenheimer, Inc., Willow Grove, Pa., offers a data sheet detailing the commercial availability of its radiometric laboratory for the measurement of luminous sources which emit light in the visible spectrum.

Principal instrument in the laboratory is a Linear Visible Spectroradiometer manufactured by Beckman Instruments to Oppenheimer's specifications. Sensitivity of the laboratory instrument permits measurements on low intensity sources with brightness levels below 1-foot-lambert. The normalized spectral response of the source under test is permanently recorded using a chart recorder and the CIE chromaticity coordinates are calculated using a computer which is an integral part of the spectroradiometer.

The laboratory is also equipped with a photometer for brightness measurements. Both the spectroradiometer and photometers are calibrated using standards traceable to N.B.S.

Circle Reader Service Card No. 53

Reference Guide

A 16-page quick reference guide describes over 100 different cathode-ray tubes for industrial and military display applications.

The guide contains sections describing high resolution CRT's; ruggedized tube, yoke and shield packages; electrostatic focus and deflection CRT's; round and rectangular magnetic deflection CRT's; and special tube and component assemblies. It also gives tube base diagrams and a list of pertinent literature that is available from Westinghouse Electronic Tube Div., Elmira, N.Y.

Circle Reader Service Card No. 54

Hard Copy Generator System

A four-page, two-color fully detailed brochure on its RAPCOR Hard Copy Generator System for computer or video outputs is offered by the manufacturer, OPTOMECHANISMS Inc., Plainview, Long Island, N.Y. The Series 725 unit records dynamic data and imagery, on the instant of display, or readout, and can turn out 8½" x 11" copies, comparable to reproducible quality prints, at an input rate of three to four sheets per second. The brochure describes the system's capability for recording information displayed on a video monitor or CRT, including alphanumeric, graphical, and continuous tone imagery. A system diagram demonstrates the automatic operation of the RAPCOR System for rapid dry hard copy outputs.

Circle Reader Service Card No. 55

Bite Indicators

Minelco, Holbrook, Mass., is offering data sheets describing the electrical, mechanical, and environmental specifications of six "Go-No-Go" BITE (Built-In Test Equipment) indicators. The literature details application of the indicators, and provides actual size photographs and schematic diagrams.

Model BHGM is a latching indicator with push-button manual reset function which performs magnetically. There is no direct mechanical linkage. An electrical impulse is used to trigger this unit and it has negligible power consumption.

Model BHG21 is a single coil magnetic latching unit with a high degree of visibility. There is no mechanical wear, no filament burn out, and negligible consumption.

Model BIS21 is a self-restoring type indicator for ON-OFF monitoring such as indication of power loss. It is capable of being operated at full rated voltage over a temperature range of from 65 degrees C through +125 degrees C. Electromagnetic, the indicator has no filament burn out and offers strong visibility.

Circle Reader Service Card No. 56

Software System

Adage, Inc., Boston, has published an eight page brochure describing the comprehensive standard software system furnished with the Adage Graphics Terminal. Called AMOS, this system provides efficient communication with a remote central processor and convenient local control of displayed images. The capability provided by AMOS makes possible close, on-line interaction between the operator and his computing facility.

Included in the AMOS brochure are descriptions of the resident monitor, compiler, macro-assembler, and the display editor, graphics operator routines, graphics applications programs, and utility and service routines.

Circle Reader Service Card No. 57

Graphic Display Unit

SDS Model 7580 Graphic Display Unit, a cathode-ray tube display device for use with Sigma 5 and Sigma 7 computers, is described in a new data sheet.

The Model 7580 displays computer output data dynamically in a graphic form that is convenient and timely for the operator. Its use enhances man/machine communication—especially in on-line, real-time applications.

Included in the data sheet are physical and functional descriptions of the Model 7580, which consists mainly of a display console and a primary controller. Also briefly described are the device's major features and functions and basic specifications.

Circle Reader Service Card No. 58

Folder Describes Products Line

Milgo Electronic Corp., Miami, has published a folder illustrating the firm's line of data communication products. The literature provides a condensed description of Milgo's MODEM 4400 data sets and companion equipment. The data sets are available in models that transmit digital data at rates of 2000 bps, 2400 bps and 4800 bps over unconditioned voice frequency channels.

The folder includes a brief technical summary of three models of data sets, specialized voice adapters for voice/data transmission and transmission test equipment.

Circle Reader Service Card No. 59

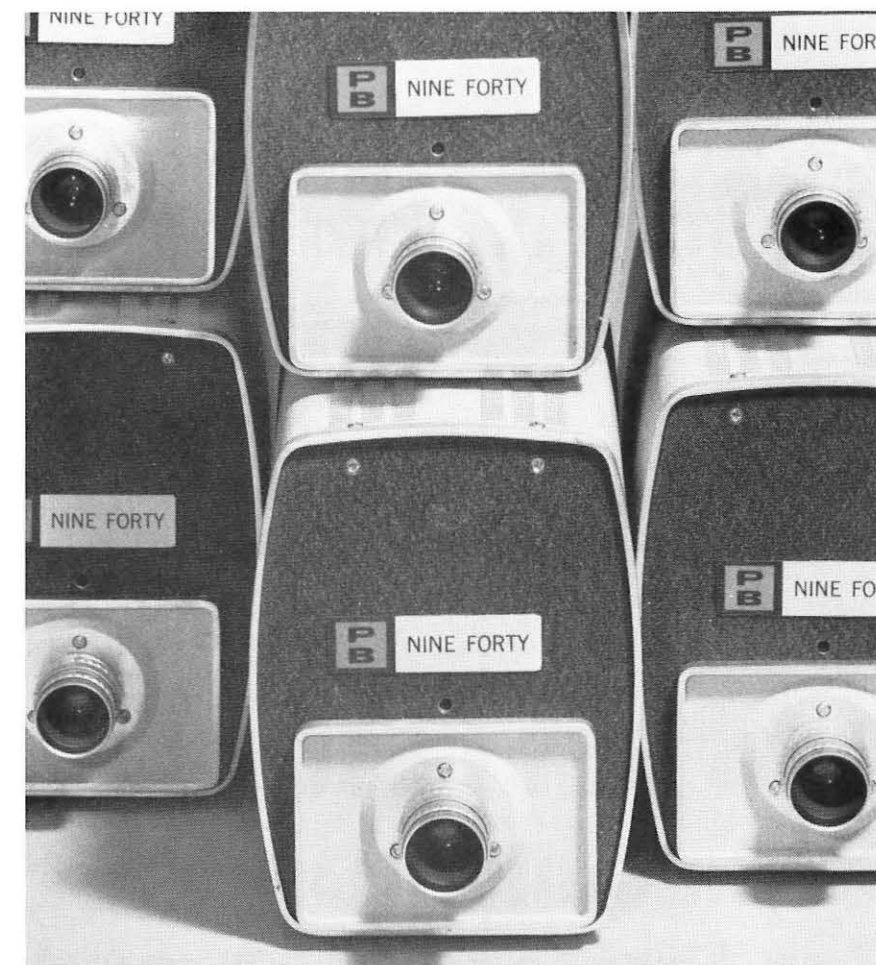

Can a fine fine-scan camera be sold at a low, low price?

YES. At a cost roughly half that of comparable cameras, the PB940 offers unmatched value for microscope work, document reading, data transfer, quality control. You get:

- Positive 2:1 interlace at 875 or 525 scan rates as standard equipment.
- Class A separate field mesh vidicon as std. equipment.



THE VALUE LINE

And only the versatile Packard Bell PB940 offers you a choice of these three options:

- Crystal-controlled random interlace at 1 of 5 scan rates.
- External EIA drives in full compliance with RS170.

- Remote control. Write today for full information and prices on the PB940 camera. F-88

Packard Bell

649 Lawrence Drive, Newbury Park, Calif. 91320. Tel: (805) 498-6601

Circle Reader Service Card No. 60

replace
these...

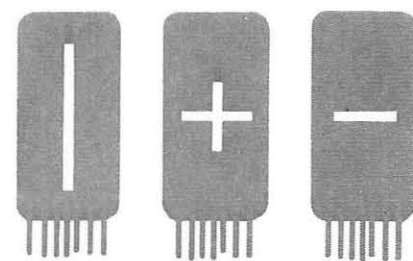

with
this...

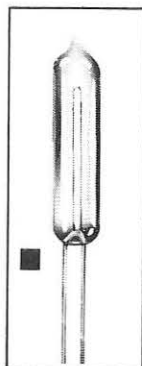

save more than \$3.00 ea.

New Low Cost Replacement for Numeral 1, + and - Readouts!

The Signalite A261 neon lamp has been designed to replace digital readout tubes in over range, positive and minus display of digital voltmeters, and similar readout equipment. The lighted electrode length is comparable to standard readouts. The low cost A261 neon lamp also has a space saving advantage and long life.

Signalite

INCORPORATED

NEPTUNE, NEW JERSEY 07753
Telephone: (201) 775-2490



A General Instrument Company

A261 Neon Lamp Priced As Low As 30¢

Write for detailed specification sheet

305

SID Sustaining Members

ADAMS ASSOCIATES
Bedford, Massachusetts

AEROSPACE CORPORATION
San Bernardino, California

CBS LABORATORIES
227 High Ridge Road
Stamford, Connecticut

GRAPHIC SYSTEMS DIVISION
Computer Industries Inc.
14761 Califa Street
Van Nuys, California 91401

BUNKER-RAMO CORPORATION
Canoga Park, California

BURROUGHS CORPORATION
Defense, Space & Special Systems Group,
Paoli, Pennsylvania

CELCO
(Constantine Engineering Labs. Co.)
Mahwah, New Jersey

COMMUNICATIONS & ELECTRONICS DIV.
Philco-Ford Corporation
A Subsidiary of Ford Motor Company
Willow Grove, Pennsylvania

CONRAC DIVISION
Conrac Corporation
600 North Rimsdale Ave.
Covina, California 91722

ELECTRONIC COMPONENTS GROUP
Div., Sylvania Electronic Products Inc.
Seneca Falls, New York 13080

GENERAL ATRONICS CORPORATION
Electronic Tube Division
1200 East Mermaid Lane
Philadelphia, Pennsylvania 19118

HUGHES AIRCRAFT COMPANY
Culver City, California 90230

HUGHES AIRCRAFT COMPANY
Vacuum Tube Products Div.
Oceanside, California

IBM CORPORATION
Armonk, N.Y.

NAC INCORPORATED
7-1 Ginzanishi
Chuo-Ku, Tokyo, Japan

RADIATION INC.
Melbourne, Florida

STROMBERG CARLSON CORP.
Data Products, San Diego, California

SYNTRONIC INSTRUMENTS INC.
100 Industrial Road, Addison, Illinois

THOMAS ELECTRONICS, INC.
100 Riverview Drive
Wayne, New Jersey 07470

TRANSISTOR ELECTRONICS CORPORATION
Minneapolis, Minnesota

High Voltage CRT Power Supplies Custom Designed



This custom designed Head-Up Display power supply met the requirements listed below and solved a unique space and weight problem as well.

- Outputs:
15 KVDC, 400 μ a pk.
1.7 KV (adj. 1.4 to 2.0 KV),
 $\pm 30 \mu$ a
300 VDC, $\pm 15 \mu$ a
- Ripple: 0.5%
- Regulation $\pm 0.1\%$
- Volume: less than 50 cu. in.
- Weight: 3 1/4 lbs.
- Temperature:
-55°C to 110°C
- Ref. to MIL-STD-826
MIL-E-5400
- Input:
115 V, 400 cps MIL-STD-704

Try stumping us with your problem. We'll put everything we have into solving it and probably come up with a design that saves weight and space. Write or call for details today.

AMP

INCORPORATED

CAPITRON DIVISION
155 Park Street • Elizabethtown, Pa.
717-367-1105 • TWX: 510-675-4561

Circle Reader Service Card No. 62

INFORMATION DISPLAY, September/October 1968

ID Advertisers

Adams Associates	53
AMP Inc., Capatron Div.	63
Beta Instrument Corp.	67
Burroughs Corp.	5
California Computer Products Inc.	8
CELCO (Constantine Engineering Labs. Co.)	12
Constantine Engineering Labs. Co. (CELCO)	12
Control Data Corp.	Back Cover
Dialight Corp.	14
Fairchild Corp., Dumont Electronics Div.	57
General Atronics Corp.	59
General Electric Co., Information Systems Equipment Div.	49
General Precision, Link Div.	22
Hewlett Packard, Colorado Springs Div.	21
Industrial Electronics Engineers	20
Information Control Corp.	58
Information Displays, Inc.	52
Kaye Scientific	58
Keuffel and Esser	64
Litton Industries, Electron Tube Div. ..	48
Magnetic Radiation Labs. Inc.	54
Mast Development Co.	54
Microswitch, Div. of Honeywell	13
Milgo Electronic Corp.	7
M-O Valve Co. Ltd.	46
Monsanto	60
Packard Bell Space and Systems Div... ..	61
Perfection Mica Co.	56
Raytheon Company	18 & 19
Rauland Corp.	2
Signalite Inc.	62
Stromberg Datagraphics Inc.	15
Sylvania, Electric Products Div.	11
Syntronic Instruments, Inc.	17
Thomas Electronics Inc.	16
Tung-Sol Electronics	47
Wanlass Electric	63
Warnecke Electronic Tubes	9
Welch Allyn	55
Video Color Corp.	51

NOW! LESS THAN \$30.00*!! AND THREE YEARS TO QUALIFY**

PHASE II OF WANLASS' O.E.M. SAME LOW PRICES! IMPROVED SPECIFICATIONS

AND NOW THREE RATINGS TO CHOOSE FROM—30-60-120 WATTS WITH FOUR VOLTAGE RANGES EACH! FROM 3.6-60 V.D.C.

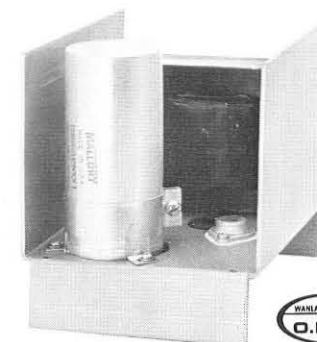

WANLASS TYPE 60-OEM-3



SPECIFICATIONS

A. C. INPUT:	105-125V, 57-63Hz, 1 phase
D. C. OUTPUT:	{ 3.6 to 60 watts at 60 watts or 5 amperes maximum
REGULATION:	$\pm 1\%$ for $\pm 10\%$ line change $\pm 1\%$ for no load to full load
RIPPLE:	0.1% ± 10 MV rms maximum
GROUNDING:	Floating output; either positive or negative may be grounded.
PROTECTION:	Automatic short circuit protection
DIMENSIONS & WEIGHTS:	30-OEM 5"H x 5"W x 5"L; 5# max. 60-OEM 7"H x 5"W x 7"L; 7# max. 120-OEM 7"H x 5"W x 10"L; 12# max.
CONSTRUCTION:	Open Chassis type for OEM systems
TEMPERATURE:	0°C to 45°C

PRICES MODEL NO. 60-OEM-3

1 - 9	\$50.00
10 - 24	47.50
25 - 49	45.00
50 - 99	42.50
100 - 999	36.00
1,000 - 9,999	31.00
*10,000 - up	27.00

**** ASK US ABOUT OUR EXTENDED CONTRACT PLAN WHICH MAY QUALIFY YOU FOR THE LOWEST PRICE BASED ON YOUR REQUIREMENTS FOR THE NEXT THREE (3) YEARS!**



WANLASS ELECTRIC COMPANY
A SUBSIDIARY OF AMBAC INDUSTRIES INC.

1540 EAST EDINGER AVENUE
SANTA ANA, CALIFORNIA 92707
PHONE 714 546-8990 TWX 910-595-1526

Now K&E offers digital plotting paper and film any way you want it.

(We'll even give you some free.)

K&E's new COMSTOC™ fills the crying need for a truly comprehensive, compatible line of digital plotting papers and film. **One that matches the special individualized requirements of people in engineering, highway planning, business, meteorology and many other fields.**

It's a natural for us—and for you. K&E is the company that already makes over 10,000 products related to the business of getting information down on paper and reproducing it efficiently.

So it's only logical that Comstoc joins our family with a line that includes: 1) high transparency 100% rag tracing paper, suitable for plotting in either ink or pencil, and admirable for reproduction; 2) ALBANIZED® copy paper that produces jet-black, smudge-free copies with conventional reproduction methods; 3) film, with the famous K&E drafting surface, virtually indestructible because it's based on Mylar®, not acetate.

And, when it comes to "specials", they're our stock-in-trade. We can develop any kind of grid you want, on rolls from 12" to 31", and provide it in repeats of up to 54". (We can even produce Federal Aid Sheets in continuous form for you, on rolls with repeats, printed on the reverse side to help assure the sharpest reproduction.)

Comstoc materials can be used on practically all major-name drum-type equipment. Our prices are competitive...but Comstoc performance is hard to beat. As sticklers for quality control we engineer consistency in for you.

See for yourself. Send for free samples of Comstoc paper and film. You won't believe digital plotting media could be so compatible.

 CREATIVE PRODUCTS FOR THE CREATIVE ENGINEER
KEUFFEL & ESSER CO.

KEUFFEL & ESSER COMPANY
300 Adams St., Hoboken, N.J.

Yes, I'd like to get free samples of K&E Comstoc digital plotting paper and film.

Name _____

Position _____

Company _____

City _____ State _____ Zip Code _____



Beta • graphics™

HARD-COPY CRT PRINTER

MODEL HC610



PRODUCES 8½ X 11" PRINTS OF COMPUTER-GENERATED GRAPHICS AND ALPHANUMERICS IN SECONDS . . . COMPLETELY DRY (NO LIQUIDS USED).

Model HC610 is designed to be interfaced to a computer, coupled to a display controller or slaved to any graphical computer display.

The Betagraphics Printer is a random-access X-Y device, featuring high-speed magnetic deflection, geometry correction and dynamic focus. Full format settling time is less than 12 microseconds, point-plotting rate is 500,000 points per second, line-writing rate is 2 microseconds per inch and character-writing bandwidth is greater than 1 megahertz.

Operation is simple, with only three controls in addition to the power switch — an exposure TIMER, an EXPOSE-DEVELOP switch for single exposure, development and delivery, and an EXPOSE switch for the multiple overlay or slow-buildup mode. All command and status interface signals are available for remote operation.

The Betagraphics line of peripheral display devices is here, now, to give you high quality computer graphics at reasonable prices. We'll be happy to send you complete specifications.



Beta Instrument Corp.

377 ELLIOT ST., NEWTON UPPER FALLS
MASSACHUSETTS / TEL. 617 • 969-6510

Beta • graphics™

MICROFILM CRT RECORDER

MODEL MR606



PRODUCES HIGH-RESOLUTION 35 MM. MICROFILM RECORDINGS OF COMPUTER-GENERATED GRAPHICS AND ALPHANUMERICS.

Model MR606 is designed to be interfaced to a computer, coupled to a display controller or slaved to any graphical computer display.

The Betagraphics Recorder is a random-access X-Y device, featuring high-speed magnetic deflection, geometry correction of the image and dynamic focus of the electron beam. 1500 x 1500 resolvable elements are produced on film in a double-frame format. Positive fixed-pin registration provides ±.0005" frame to frame registration accuracy.

Operation is simple, with only two controls in addition to the power switch — an EXPOSE-ADVANCE switch for single exposure and frame advance and an EXPOSE switch for the multiple overlay or slow-buildup mode. All command and status interface signals are available for remote operation.

The Betagraphics line of peripheral display devices is here, now, to give you high quality computer graphics at reasonable prices. We'll be happy to send you complete specifications.



Beta Instrument Corp.

377 ELLIOT ST., NEWTON UPPER FALLS
MASSACHUSETTS / TEL. 617 • 969-6510